



# MELSERVO-H

ADVANCED SERVO SYSTEM



# Servo Technology Transformed by a New Control Algorithm

## Reduced Settling Time

The MR-H settling time has been sharply reduced when compared to conventional servo systems. The ability of the MR-H to respond quickly and precisely to a reference change is due to the high-performance Reduced Instruction Set Computer (RISC) platform, and the patented model reference adaptive control logic. These features make the MR-H ideal for applications which require high speed positioning.

Stationary Settling Time — Comparison with Conventional Products

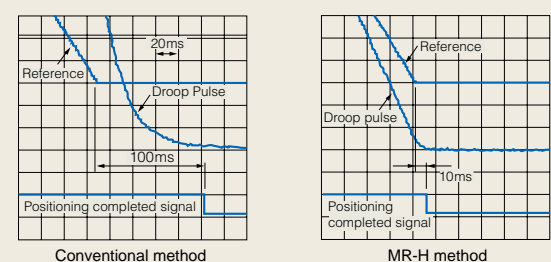

## Stable Performance at Very Low Speed

The MR-H has the most stable performance at low speed in its class of devices. This is made possible through the application of a high-resolution serial encoder and the model-reference adaptive control theory. This low speed performance makes the MR-H well suited for low speed machining operations.

Measurement with motor operated at 0.5 rpm

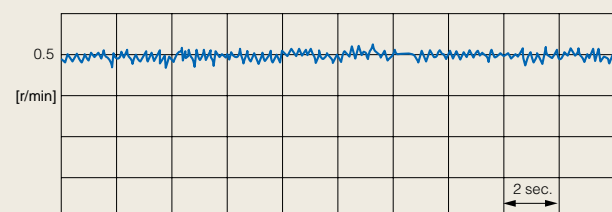

## Real-Time Automatic Tuning

The patented model-reference adaptive tuning virtually eliminates the time-consuming process of manually tuning the amplifier. During operation, the MR-H's internal gain settings are constantly updated to the optimum level. The result is consistently stable control, even under fluctuating load conditions. With Real-Time Automatic Tuning the MR-H is ideal for winding applications.

Measurement of speed response when load's moment of inertia is changed during operation

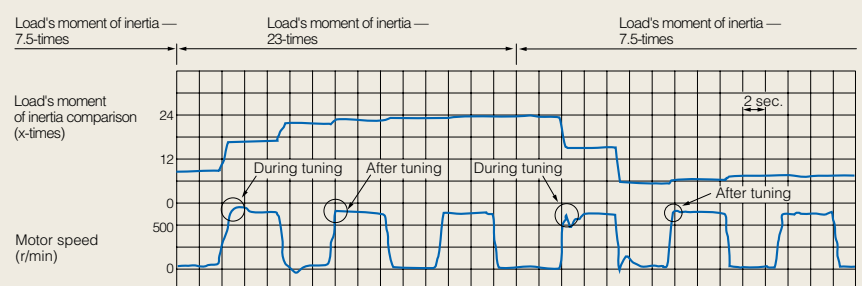

# MELSERVO-H

## Easy Operation

An optional parameter unit with a 13 character, 4 line LCD display makes it easy to utilize the outstanding operating features of the MR-H series:

### ■ Main features

- Parameter setting
- Parameter copying
- Operation monitor
- Alarm diagnostics
- Trouble-shooting
- An array of test modes



## Absolute Positioning (ABS)

Thanks to Mitsubishi's unique absolute positioning (ABS) it is possible to construct ABS systems with Mitsubishi's multi-purpose MELSEC-A positioning units by merely using a motor with an ABS encoder. There's no need for home position return after power has been turned off.

- A sample program illustrating construction of an ABS system with the AD71 and AD75P are available.
- A motor equipped with a ABS encoder and a battery (separate option) are required.



## RS-232C Communications (Computer Link)

An RS-232C communication port comes as standard equipment in the MR-H-AN series. This port allows expansion of the system and operating environment through connection to a PLC or personal computer.



## Simple Wiring

- In this revolutionary system, all data is transmitted with just one pair of signals (four pairs with the power supply and ABS power supply). A dedicated gate array for the encoder has been developed, enabling data to be transmitted via serial communications. The wiring is simpler than ever.
- High-resolution 16384 P/rev encoder is standard. High-resolution positioning of 0.022 degrees can be achieved with the motor shaft and high speed feed of 49m/min in feed units of 1 $\mu$ m.
- Optical communications are optional, greatly facilitating long-distance wiring.

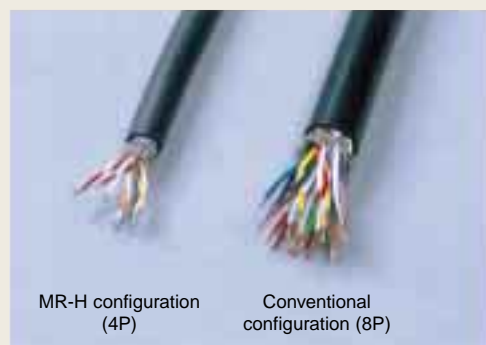

# Rating Table

## Servomotor rating tables

Specifications	Type	Servomotor series	HC-MF series (Ultra-low inertia / Low capacity)					HA-FF series (Low inertia / Low capacity)				
			MR053 (BG)	MF13 (BG)	MF23 (BG)	MF43 (BG)	MF73 (BG)	FF053 (BG)	FF13 (BG)	FF23 (BG)	FF33 (BG)	
		Servomotor type HC-										
		Servo-amp type MR-	H200_N	H400_N	H600_N	H1000_N	H1000_N	H200_N	H400_N			
Power facility capacity (kVA) (note 2)			0.3					0.3				
Continuous characteristics	Output rating (kW)		50	100	200	400	750	50	100	200	300	
	Torque rating [N·m (kgf·cm)]		0.16 (1.62)	0.32 (3.25)	0.64 (6.5)	1.3 (13.0)	2.4 (24.4)	0.16 (1.62)	0.32 (3.25)	0.64 (6.5)	0.95 (9.7)	
Maximum torque	[N·m (kgf·cm)]		0.48 (4.86)	0.95 (9.74)	1.9 (19.5)	3.8 (39.0)	7.2 (73.1)	0.48 (4.86)	0.95 (9.74)	1.9 (19.5)	2.9 (29.2)	
Rated speed	(r/min)		3000					3000				
Maximum speed	(r/min)		4500					4000				
Permissible instantaneous rotation speed	(r/min)		5175					4600				
Power rate	(kW/s)		13.47	34.13	46.02	116.55	94.43	4.0	10.2	11.7	18.1	
Rated current	(A)		0.85		1.5	2.8	5.1	0.6	1.1	1.3	1.9	
Maximum current	(A)		2.6		5.0	9.0	18.0	1.8	3.3	3.9	5.7	
Regeneration braking frequency (times/min) (note 3)	With no options		(note 4)					(note 4)				
	MR-RB013 (10W)		(note 4)					2071	1363	370	—	
	MR-RB033 (30W)		(note 4)					(note 4)	4088	1109	—	
	MR-RB30 (300W)		—	—	—	—	—	—	—	—	—	
	MR-RB31 (300W)		—	—	—	—	—	—	—	—	—	
	MR-RB32 (300W)		—	—	—	(note 4)	—	—	—	—	(note 4)	
	MR-RB34 (300W)		—	—	—	—	—	—	—	—	—	
	MR-RB50 (500W)		—	—	—	—	—	—	—	—	—	
Moment of inertia (figures inside parentheses indicate units with B)	J ( $\times 10^{-4}$ kg·m <sup>2</sup> )		0.019 (0.022)	0.03 (0.032)	0.088 (0.136)	0.143 (0.191)	0.6 (0.725)	0.063 (0.08)	0.095 (0.113)	0.35 (0.483)	0.50 (0.633)	
	GD <sup>2</sup> (kgf·m <sup>2</sup> )		0.074 (0.086)	0.12 (0.129)	0.35 (0.543)	0.57 (0.763)	2.4 (2.9)	0.25 (0.32)	0.38 (0.45)	1.4 (1.93)	2.0 (2.53)	
Recommended load/motor inertia ratio		30 times the servomotor's moment of inertia max. (note 6)					10 times the servomotor's moment of inertia					
Speed/position detector		Resolution per encoder / servomotor rotation: 8192 P/rev (Can handle up to 32768 P/rev with special specifications. The amp is made to order.) (note 13)										
Attachments		Encoder										
Structure		Totally enclosed non ventilated (protection degree: IP44) (note 8)					Totally enclosed non ventilated (protection degree: IP44)					
Environment	Ambient temperature											
	Ambient humidity											
	Atmosphere											
	Elevation											
Vibration (note 9)							X: 19.6 m/s <sup>2</sup> (2 G) Y: 19.6 m/s <sup>2</sup> (2 G)					
Weight	kg (lb)	0.4 (0.9)	0.53 (1.2)	0.99 (2.2)	1.45 (3.2)	3.0 (6.7)	1.3 (2.9)	1.5 (3.3)	2.3 (5.1)	2.6 (5.7)		

Specifications	Type	Servomotor series	HC-SF3000/r/min series (Medium inertia / Medium capacity)					HC-RF series (Medium inertia / Medium capacity)			
			SF53 (B)	SF 103 (B)	SF153 (B)	SF203 (B)	SF353 (B)	RF103 (BG)	RF153 (BG)	RF203 (BG)	RF353 (BG)
		Servomotor type HC-									
		Servo-amp type MR-	H600_N	H1000_N	H2000_N	H3500_N	H2000_N	H3500_N	H5000_N		
Power facility capacity (kVA) (note 2)			1.0	1.7	2.5	3.5	5.5	1.7	2.5	3.5	5.5
Continuous characteristics	Output rating (kW)		0.5	1.0	1.5	2.0	3.5	1.0	1.5	2.0	3.5
	Torque rating [N·m (kgf·cm)]		1.59 (16.2)	3.18 (32.5)	4.78 (48.7)	6.37 (65.0)	11.1 (114)	3.18 (32.5)	4.78 (48.7)	6.37 (64.9)	11.1 (114)
Maximum torque	[N·m (kgf·cm)]		4.77 (48.7)	9.55 (97.4)	14.3 (146)	19.1 (195)	33.4 (341)	7.98 (81.3)	11.9 (122)	15.9 (162)	27.9 (285)
Rated speed	(r/min)		3000					3000			
Maximum speed	(r/min)		3000					4500			
Permissible instantaneous rotation speed	(r/min)		3450					5175			
Power rate	(kW/s)		3.8	7.4	11.4	9.5	15.1	67.4	120	176	150
Rated current	(A)		3.2	5.3	8.6	10.4	16.4	6.1	8.8	14.0	23.0
Maximum current	(A)		9.6	15.9	25.8	31.2	49.2	18.4	23.4	37.0	58.0
Regeneration braking frequency (times/min) (note 3)	With no options		92	71	79	37	19	1056	834	689	174
	MR-RB013 (10W)		—	—	—	—	—	—	—	—	—
	MR-RB033 (30W)		—	—	—	—	—	—	—	—	—
	MR-RB30 (300W)		—	—	—	—	45	—	—	1589	401
	MR-RB32 (300W)		552	267	—	—	—	—	—	—	—
	MR-RB34 (300W)		—	—	183	86	—	2437	1924	—	—
MR-RB50 (500W)		—	—	—	—	74	—	—	2648	669	
MR-RB54 (500W)		—	—	305	143	—	4061	3206	—	—	
Moment of inertia (figures inside parentheses indicate units with B)	J ( $\times 10^{-4}$ kg·m <sup>2</sup> )		6.6 (8.6)	13.7 (15.7)	20.0 (22)	42.5 (52.5)	82.0 (92)	1.5 (1.85)	1.9 (2.25)	2.3 (2.65)	8.6 (11.8)
	GD <sup>2</sup> (kgf·m <sup>2</sup> )		26.5 (34.5)	54.8 (62.8)	79.8 (87.8)	170 (210)	328 (368)	6 (7.4)	7.6 (9.0)	9.2 (10.6)	34.4 (47.2)
Recommended load/motor inertia ratio		15 times the servomotor's moment of inertia max. (note 6)					5 times the servomotor's moment of inertia max.				
Speed/position detector		Resolution per encoder / servomotor rotation: 16384 P/rev (Can handle up to 131072 P/rev with special specifications. The amp is made to order.) (note 13)									
Attachments		Encoder, Oil seal									
Structure		Totally enclosed non ventilated (protection degree: IP65)					Totally enclosed non ventilated (protection degree: IP65) (note 11)				
Environment	Ambient temperature										
	Ambient humidity										
	Atmosphere										
	Elevation										
Vibration (note 9)		X: 9.8 m/s <sup>2</sup> (1 G) Y: 24.5 m/s <sup>2</sup> (2.5 G)			X: 19.6 m/s <sup>2</sup> (2 G) Y: 49 m/s <sup>2</sup> (5 G)		X: 9.8 m/s <sup>2</sup> (1 G) Y: 24.5 m/s <sup>2</sup> (2.5 G)				
Weight	kg (lb)	5.0 (11.0)	7.0 (15.4)	9.0 (19.8)	12.0 (26.5)	19.0 (41.9)	3.9 (8.60)	5.0 (11.0)	6.2 (13.7)	12.0 (26.5)	

### Notes:

- Special specifications are available for applications where oil or water may splash onto the mechanism.
- The power supply capacity varies with the power supply impedance.
- The regenerative brake frequency shown is the permissible frequency for decelerating a stand-alone motor from rate r/min to a stop. When under load, however, the value becomes the table value divided by (m+1) where m is the load inertia moment divided by the motor inertia moment. When the rated r/min is exceeded, the regenerative brake frequency is inversely proportional to the square of (Operating speed/rated speed). When the operating r/min varies frequently or when regeneration is constant (as with vertical feeds), find the heat regenerated (W) while operating and do not exceed the permissible value.
- There is no limit on frequency of regeneration if the effective torque is within the rated torque range. The maximum load inertia moment ratio recommended, however, is  $\times 30$ .
- There is no limit on frequency of regeneration if the effective torque is within the rated torque range. The maximum load inertia moment ratio recommended, however, is  $\times 10$ .

# Rating Table

capacity)		HC-SF1000r/min series (Medium inertia / Medium capacity)					HC-SF2000r/min series (Medium inertia / Medium capacity)						
FF43 (BG)	FF63 (BG)	SF81 (B)	SF121 (B)	SF201 (B)	SF301 (B)	SF52 (BG)	SF102 (BG)	SF152 (BG)	SF202 (BG)	SF352 (BG)	SF502 (BG)	SF702 (BG)	
H40_N	H60_N	H100_N	H200_N		H350_N	H60_N	H100_N	H200_N		H350_N	H500_N	H700_N	
0.9	1.1	1.5	2.1	3.5	4.8	1.0	1.7	2.5	3.5	5.5	7.5	10.0	
400	600	0.85	1.2	2.0	3.0	0.5	1.0	1.5	2.0	3.5	5.0	7.0	
1.3 (13.0)	1.9 (19.5)	8.12 (82.8)	11.5 (117)	19.1 (195)	28.6 (292)	2.39 (24.4)	4.78 (48.7)	7.16 (73.1)	9.55 (97.4)	16.7 (170)	23.9 (244)	33.4 (340)	
3.8 (39.0)	5.7 (58.5)	24.4 (248)	34.4 (351)	57.3 (585)	85.9 (877)	7.16 (73.1)	14.4 (146)	21.6 (219)	28.5 (292)	50.1 (510)	71.6 (730)	100 (1022)	
1000						2000							
		1500	1200			3000			2500		2000		
		1725	1380			3450			2850		2300		
17.2	30.1	32.9	30.9	44.5	81.3	8.7	16.7	25.6	21.5	34.1	56.5	69.7	
2.5	3.6	5.1	7.1	9.6	16.0	3.2	6.0	9.0	11.0	17.0	28.0	37.0	
7.5	10.6	15.3	21.3	28.8	48.0	9.6	18.0	27.0	33.0	51.0	84.0	111.0	
750	600	440	335	174	118	207	170	179	84	43	39	32	
-	-	-	-	-	-	-	-	-	-	-	-	-	
-	-	-	-	-	272	-	-	-	-	100	90	-	
-	-	-	-	-	-	-	-	-	-	-	-	57	
3983	3046	1649	-	-	-	1241	638	-	-	-	-	-	
-	-	-	774	401	-	-	-	412	193	-	-	-	
-	-	-	-	-	453	-	-	-	-	167	150	-	
-	-	-	-	-	-	-	-	-	-	-	-	95	
-	-	-	1290	669	-	-	-	687	322	-	-	-	
0.98 (1.325)	1.20 (1.55)	20.0 (22.0)	42.5 (52.5)	82.0 (92.0)	101 (111)	6.6 (8.6)	13.7 (15.7)	20.0 (22.0)	42.5 (52.5)	82.0 (92.0)	101 (111)	160 (170)	
3.9 (5.3)	4.8 (6.2)	79.8 (87.8)	170 (210)	328 (368)	404 (444)	26.5 (34.5)	54.8 (62.8)	79.8 (87.8)	170 (210)	328 (368)	404 (444)	640 (680)	
max. (note 6)													
15 times the servomotor's moment of inertia max. (note 6)													
Resolution per encoder / servomotor rotation: 16384 P/rev													
(Can handle up to 131072 P/rev with special specifications. The amp is made to order.) (note 13)													
Encoder, Oil seal													
except connector (note 8)						Totally enclosed non ventilated (protection degree: IP65)							
0 to 40°C (32 to 104°F) (non freezing), storage: -15 to 70°C (5 to 158°F) (non freezing)													
80% RH max. (non condensing), storage: 90% RH max. (non condensing)													
Indoors (no direct sunlight); no corrosive gas, inflammable gas, oil mist, or dust													
1000 meters or less above sea level													
		X: 9.8 m/s <sup>2</sup> (1 G) Y: 24.5 m/s <sup>2</sup> (2.5 G)	X: 19.6 m/s <sup>2</sup> (2 G) Y: 49 m/s <sup>2</sup> (5 G)	X: 11.7 m/s <sup>2</sup> (1.2 G) Y: 29.4 m/s <sup>2</sup> (3 G)	X: 9.8 m/s <sup>2</sup> (1 G) Y: 24.5 m/s <sup>2</sup> (2.5 G)	X: 19.6 m/s <sup>2</sup> (2 G) Y: 49 m/s <sup>2</sup> (5 G)	X: 11.7 m/s <sup>2</sup> (1.2 G) Y: 29.4 m/s <sup>2</sup> (3 G)	X: 9.8 m/s <sup>2</sup> (1 G) Y: 24.5 m/s <sup>2</sup> (2.5 G)	X: 19.6 m/s <sup>2</sup> (2 G) Y: 49 m/s <sup>2</sup> (5 G)	X: 11.7 m/s <sup>2</sup> (1.2 G) Y: 29.4 m/s <sup>2</sup> (3 G)	X: 9.8 m/s <sup>2</sup> (1 G) Y: 24.5 m/s <sup>2</sup> (2.5 G)	X: 11.7 m/s <sup>2</sup> (1.2 G) Y: 29.4 m/s <sup>2</sup> (3 G)	
4.2 (9.3)	4.8 (10.6)	9.0 (19.8)	12.0 (26.5)	19.0 (41.9)	23.0 (50.7)	5.0 (11.1)	7.0 (15.4)	9.0 (19.8)	12.0 (26.5)	19.0 (41.9)	23.0 (50.7)	32.0 (70.6)	

HC-UF2000r/min series (Flat medium capacity)						HC-UF3000r/min series (Flat low capacity)				HA-LH series (Low inertia / High capacity)		
RF503 (BG)	UF72 (B)	UF152 (B)	UF202 (B)	UF352 (B)	UF502 (B)	UF13 (B)	UF23 (B)	UF43 (B)	UF73 (B)	LH11K2	LH15K2	LH22K2
H500_N	H100_N	H200_N	H350_N	H500_N	H500_N	H10_N	H40_N	H60_N	H100_N	11K_N	15K_N	22K_N
7.5	1.3	2.5	3.5	5.5	7.5	0.3	0.5	0.9	1.3	16	22	33
5.0	0.75	1.5	2.0	3.5	5.0	0.1	0.2	0.4	0.75	11	15	22
15.9 (162)	3.58 (36.5)	7.16 (73.1)	9.55 (97.4)	16.7 (170)	23.9 (244)	0.32 (3.25)	0.64 (6.5)	1.3 (13.0)	2.4 (24.4)	52.5 (536)	71.6 (731)	105 (1071)
39.7 (405)	10.7 (110)	21.6 (219)	28.5 (292)	50.1 (510)	71.6 (730)	0.95 (9.74)	1.9 (19.5)	3.8 (39.0)	7.2 (73.1)	158 (1610)	215 (2190)	263 (2680)
2000						3000				2000		
3000						4500				2000		
3450						5175				2300		
211	12.3	23.2	23.9	36.5	49.6	15.5	19.2	47.7	9.66	235	177	278
28.0	5.4	9.7	14.0	23.0	28.0	0.76	1.5	2.8	4.3	68.0	87.0	126
70.0	16.2	29.1	42.0	69.0	84.0	2.5	4.95	9.24	12.9	204	261	315
121	179	137	93	44	31	(note 10)	2530	1669	165	85	70	55
-	-	-	-	-	-	2241	-	-	-	-	-	-
-	-	-	-	-	-	(note 10)	-	-	-	-	-	-
278	-	-	215	102	72	-	-	-	-	-	-	-
-	672	-	-	-	-	-	(note 10)	-	619	-	-	-
-	-	315	-	-	-	-	-	-	-	-	-	-
464	-	-	358	169	119	-	-	-	-	-	-	-
-	-	525	-	-	-	-	-	-	-	-	-	-
12.0 (15.5)	10.4 (12.4)	22.1 (24.1)	38.2 (46.8)	76.5 (85.1)	115 (123.6)	0.066 (0.074)	0.241 (0.323)	0.365 (0.447)	5.90 (6.10)	118	290	395
48.0 (62.0)	41.6 (49.6)	88.4 (96.4)	153 (187.2)	306 (340.4)	460 (494.4)	0.264 (0.296)	0.963 (1.29)	1.46 (1.79)	23.6 (24.4)	470	1160	1580
(note 6)												
15 times the servomotor's moment of inertia max. (note 6)												
Resolution per encoder / servomotor rotation: 16384 P/rev												
(Can handle up to 131072 P/rev with special specifications. The amp is made to order.) (note 13)												
Encoder, Oil seal												
Totally enclosed non ventilated (protection degree: IP65) (note 11)						Totally enclosed fan cooled (protection degree: IP44)						
0 to 40°C (32 to 104°F) (non freezing), storage: -15 to 70°C (5 to 158°F) (non freezing)												
80% RH max. (non condensing), storage: 90% RH max. (non condensing)												
Indoors (no direct sunlight); no corrosive gas, inflammable gas, oil mist, or dust												
1000 meters or less above sea level												
		X: 9.8 m/s <sup>2</sup> (1 G) Y: 24.5 m/s <sup>2</sup> (2.5 G)	X: 19.6 m/s <sup>2</sup> (2 G) Y: 49 m/s <sup>2</sup> (5 G)	X: 11.7 m/s <sup>2</sup> (1.2 G) Y: 29.4 m/s <sup>2</sup> (3 G)	X: 9.8 m/s <sup>2</sup> (1 G) Y: 24.5 m/s <sup>2</sup> (2.5 G)	X: 19.6 m/s <sup>2</sup> (2 G) Y: 49 m/s <sup>2</sup> (5 G)	X: 11.7 m/s <sup>2</sup> (1.2 G) Y: 29.4 m/s <sup>2</sup> (3 G)	X: 9.8 m/s <sup>2</sup> (1 G) Y: 24.5 m/s <sup>2</sup> (2.5 G)	X: 19.6 m/s <sup>2</sup> (2 G) Y: 49 m/s <sup>2</sup> (5 G)	X: 11.7 m/s <sup>2</sup> (1.2 G) Y: 29.4 m/s <sup>2</sup> (3 G)	X: 9.8 m/s <sup>2</sup> (1 G) Y: 24.5 m/s <sup>2</sup> (2.5 G)	X: 11.7 m/s <sup>2</sup> (1.2 G) Y: 29.4 m/s <sup>2</sup> (3 G)
17.0 (37.5)	8.0 (17.6)	11.0 (24.3)	16.0 (35.3)	20.0 (44.1)	24.0 (52.9)	0.8 (1.8)	1.5 (3.3)	1.7 (3.7)	5.0 (11.0)	70 (154.4)	108 (238.1)	135 (297.7)

- Contact Mitsubishi if you must exceed the stated load inertia moment ratio.
- Does not include connector.
- Does not include axis penetration area or connector.
- The directions of vibration are as follows.



- Regeneration frequency is not restricted if the effective torque is within the rated torque range. However the recommended load inertia moment ratio is a maximum of 15.
- When a decelerator is attached, the decelerator portion is equivalent to IP44.
- Changing Parameter 2, and installing the cooling fan and resistor allows adjustment.
- Not compatible with models MR-H□ACN. Contact Mitsubishi for details.

# Type Designation and Servomotors

## ■ Servo-amp

# MR-H 20 A

Mitsubishi  
General-purpose  
Servo-amp  
MR-H series

A: Standard  
B: SSC-NET

Compatible motor output capacity (kW)

Symbol	HA-LH	HC-MF	HA-FF	HC-SF			HC-RF	HC-UF	
	2000 r/min	3000 r/min	3000 r/min	1000 r/min	2000 r/min	3000 r/min	3000 r/min	2000 r/min	3000 r/min
10	—	—	0.05, 0.1	—	—	—	—	—	0.1
20	—	0.05, 0.1	0.2	—	—	—	—	—	—
40	—	0.2	0.3, 0.4	—	—	—	—	—	0.2
60	0.5	0.4	0.6	—	0.5	0.5	—	—	0.4
100	—	0.75	—	0.85	1.0	1.0	—	0.75	0.75
200	1.0, 1.5	—	—	1.2, 2.0	1.5, 2.0	1.5, 2.0	1.0, 1.5	1.5	—
350	2.0	—	—	3.0	3.5	3.5	2.0	2.0	—
500	3.0, 5.0	—	—	—	5.0	—	3.5, 5.0	3.5, 5.0	—
700	7.0	—	—	—	7.0	—	—	—	—
11K	11.0	—	—	—	—	—	—	—	—
15K	15.0	—	—	—	—	—	—	—	—
22K	22.0	—	—	—	—	—	—	—	—

## ■ Servomotor

# HC-MF 05 3 □ B □ - □

Mitsubishi AC servomotors  
HC-MF series  
HA-FF series  
HC-SF series  
HC-UF series  
HC-RF series  
HA-LH□K series

Symbol	Electromagnetic brake
—	—
B	Installed

Symbol	Axial end
—	Standard*1
K	Key way*3
D	D-cut*2

(HC-MF and -UF3000 r/min series)

Symbol	Input supply format
—	Lead
C	—

(HC-SF, -RF, and -UF2000 r/min series)

Symbol	Input supply format
—	Canon connector
C	—

Notes:  
1. A key way is standard on the HA-FF23 through HA-FF63. All others have a straight shaft as standard.  
2. The D-cut works only with the HC-MF and HA-FF models of 100W or less.  
3. HC-MF□K and HC-UF□K (3000 r/min) have key.

Symbol	Rated output capacity (kW)
05	0.05
1 to 7	0.1 to 0.75
10 to 70	1.0 to 7.0
11K to 22K	11 to 22

(HA-FF series)

Input supply format		
Symbol	HA-FF	HA-FF-UE
—	Lead	—
C	—	Canon connector

Symbol	Rated (r/min)
1	1000
2	2000
3	3000

(HA-LH□K series)

Symbol	Input supply format		
	HA-LH□K	HA-LH□K-EC	HA-LH□K-UL
—	Terminal box	Terminal block	Terminal box
C	—	—	—

(HC-MF, HA-FF series)

Symbol	Non-Japanese standard compatibility
—	Standard product. Japanese compatibility
UE	Meet EN and UL/cUL standard

(HA-LH□K series)

Symbol	Non-Japanese standard compatibility
—	Standard product. Japanese compatibility
EC	Meet EN standard
UL	Meets UL/cUL standards (compliance scheduled)

Notes: 1. Make a specific enquiry regarding whether specially developed products meet standards.  
2. An incremental encoder is standard for the HA-LH□K series. The HA-LH□K2□Y series have absolute encoders.

Note: The standard specifications of the HC-SF, HC-RF, and HC-UF model series meet EN and UL/cUL standards.

# Servomotor Features and Amplifier Models

Motor series	Rated speed (maximum) (r/min)	Rated output capacity (kW)	Servomotor type with electro-magnetic brake (B)	Meets EN standards	Meets UL and cUL standards	Protective construction
<b>HC-MF series</b> <b>M</b> 	3000 (4500)	<b>0.05~0.75</b> 5 types 0.05, 0.1, 0.2, 0.4, 0.75	○	*	*	IP44
<b>HA-FF series</b> <b>F</b> 	3000 (4000)	<b>0.05~0.6</b> 6 types 0.05, 0.1, 0.2, 0.3, 0.4, 0.6	○	*	*	IP44 (IP65)
<b>HC-SF series</b> <b>S</b> 	1000 (1500: 0.85kW 1200: 1.2~3kW)	<b>0.85~3.0</b> 4 types 0.85, 1.2, 2.0, 3.0	○	○	○	IP65 (IP67)
	2000 (3000: 0.5~1.5kW 2500: 2, 3.5kW 2000: 5, 7kW~)	<b>0.5~7.0</b> 7 types 0.5, 1.0, 1.5, 2.0, 3.5, 5.0, 7.0	○	○	○	IP65 (IP67)
	3000 (3000)	<b>0.5~3.5</b> 5 types 0.5, 1.0, 1.5, 2.0, 3.5	○	○	○	IP65 (IP67)
<b>HC-RF series</b> <b>R</b> 	3000 (4500)	<b>1.0~5.0</b> 5 types 1.0, 1.5, 2.0, 3.5, 5.0	○	○	○	IP65 (IP67)
<b>HC-UF series</b> <b>U</b> 	2000 (3000: 0.75~2kW 2500: 3.5, 5kW)	<b>0.75~5.0</b> 5 types 0.75, 1.5, 2.0, 3.5, 5.0	○	○	○	IP65
	3000 (4500)	<b>0.1~0.75</b> 4 types 0.1, 0.2, 0.4, 0.75	○	○	○	IP65 except connector
<b>HC-LH□K series</b> <b>L</b> 	2000 (2000)	<b>11.0~22.0</b> 3 types 11, 15, 22	*	*	Schedule	JP44

Notes: 1. Figures in parentheses are the manufacturable range.  
2. Asterisk items are special specifications.  
3. As previously, the HA series (HA-MH, FH, SH, UH, and LH) can also be used.

# External Dimensions

## ■ Servo-amp

### ● MR-H10AN-MR-H100AN

Unit: mm (inch)

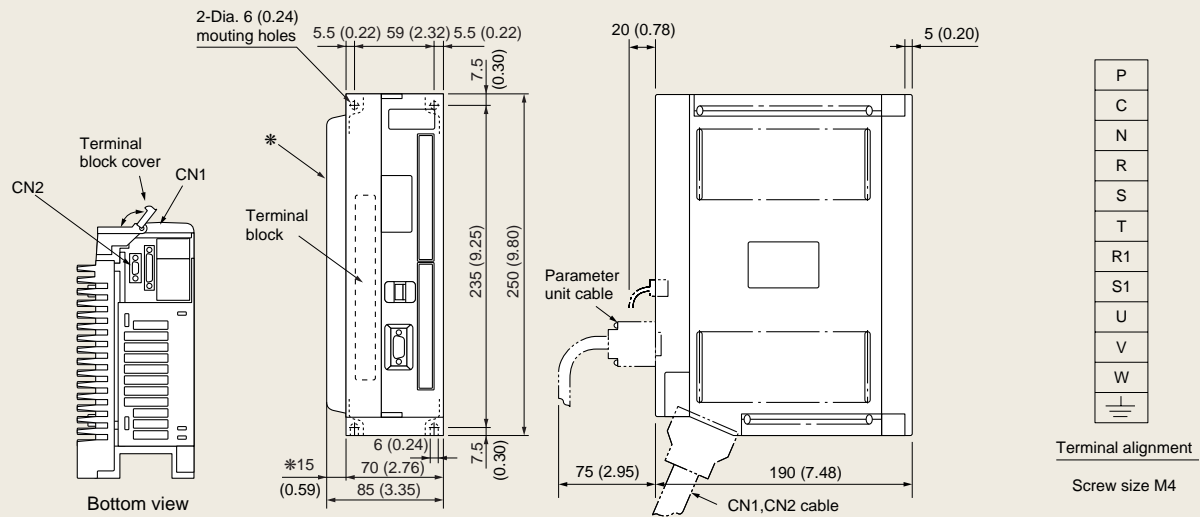

Notes: The cooling FIN is provided for the MR-H100AN.  
Width marked \* includes that of the MR-H100AN.

### ● MR-H200AN, MR-H350AN

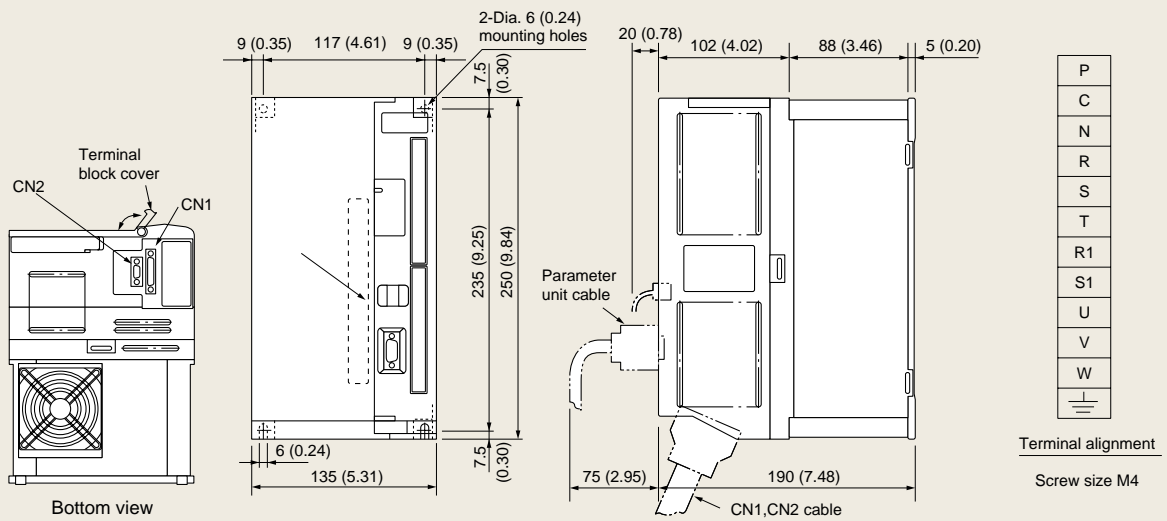

# External Dimensions

## ● MR-H500AN, MR-H700AN

Unit: mm (inch)

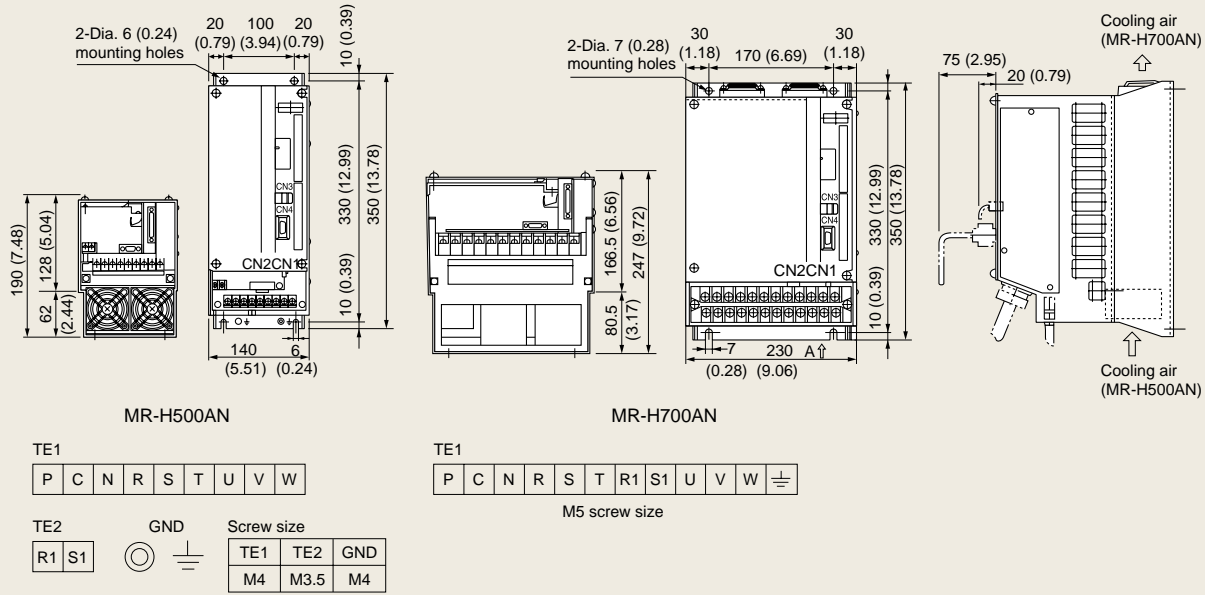

## ● MR-H11KAN~MR-H22KAN

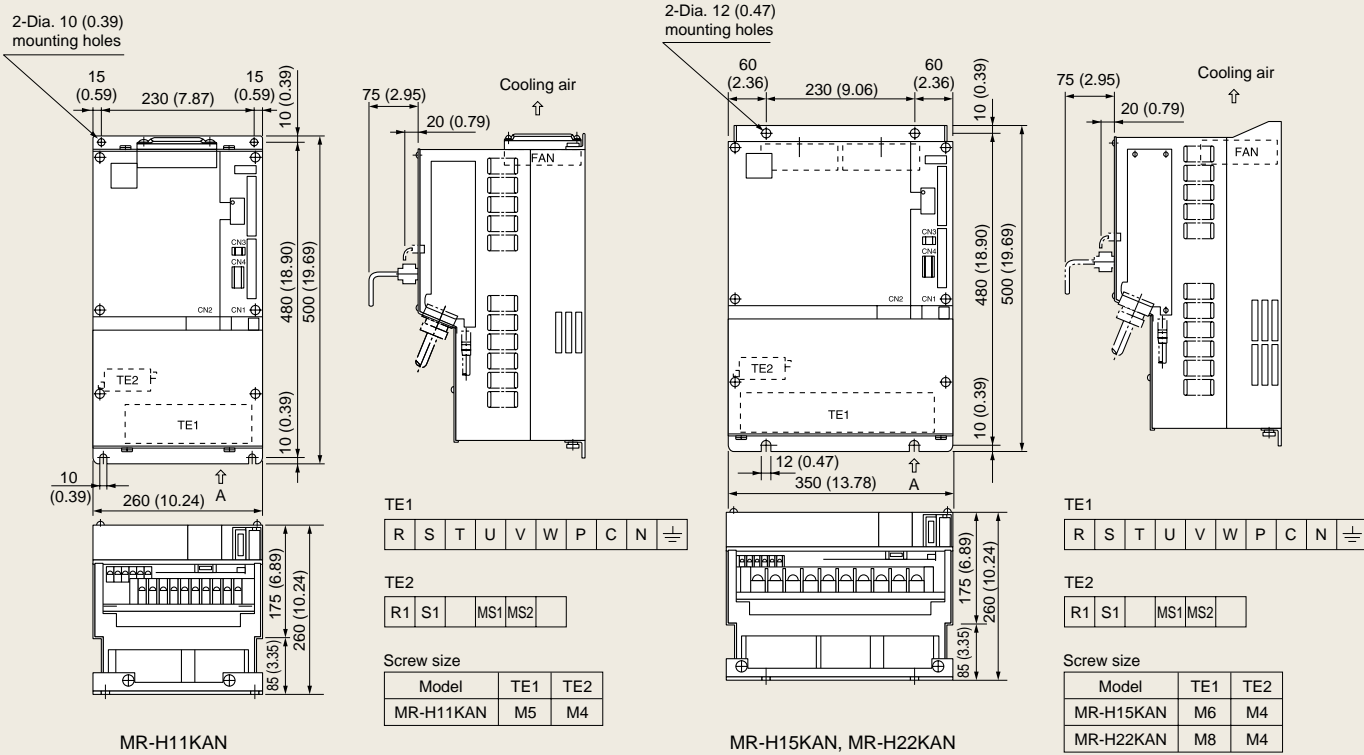

# External Dimensions

## ■ Servomotors

Unit: mm (inch)

### ● HC-MF053 (B), HC-MF13 (B)

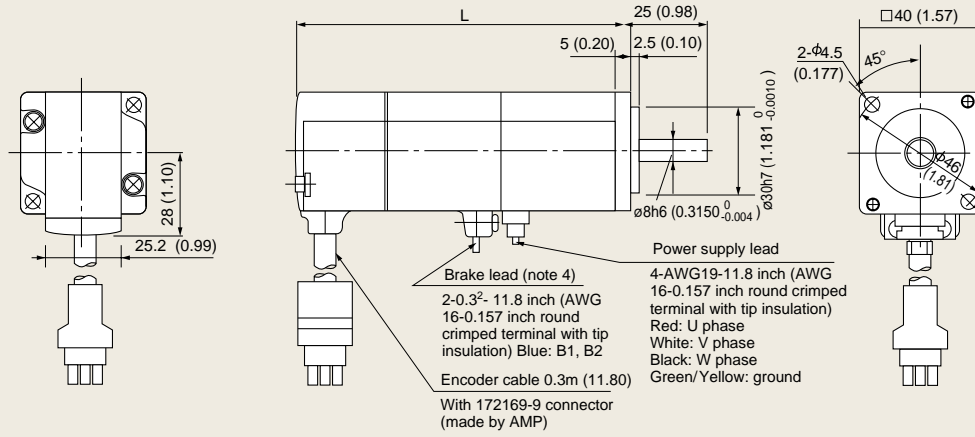

Model	Variable dimensions L
HC-MF053 (B)	81.5 (3.21) <109.5 (4.30)>
HC-MF13 (B)	96.5 (3.80) <124.5 (4.90)>

### ● HC-MF23 (B), HC-MF43 (B)

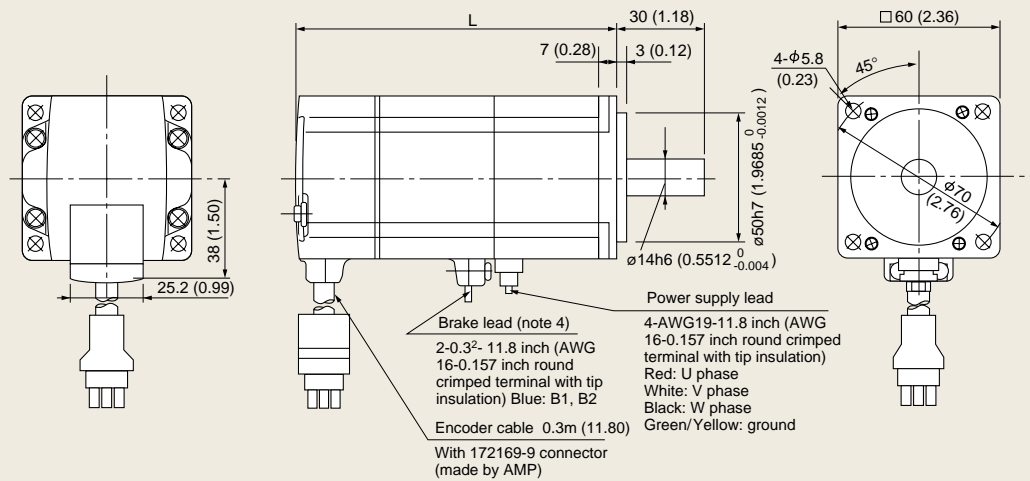

Model	Variable dimensions L
HC-MF23 (B)	99.5 (3.92) <131.5 (5.18)>
HC-MF43 (B)	124.5 (4.90) <156.5 (6.16)>

### ● HC-MF73(B)

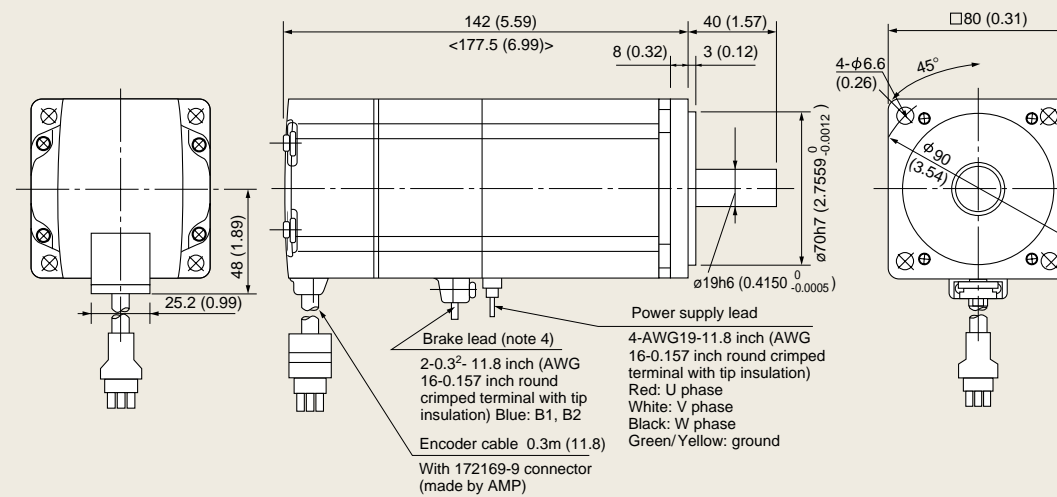

#### Notes:

1. When mounting the servomotor horizontally we recommend encoder connector be mounted downward.
2. Use a friction coupling to fasten the load.
3. Dimensions inside < > are for models with electromagnetic brakes.
4. Only for models with electromagnetic brakes.

# External Dimensions

## ● HA-FF053 (B), HA-FF13 (B)

Unit: mm (inch)

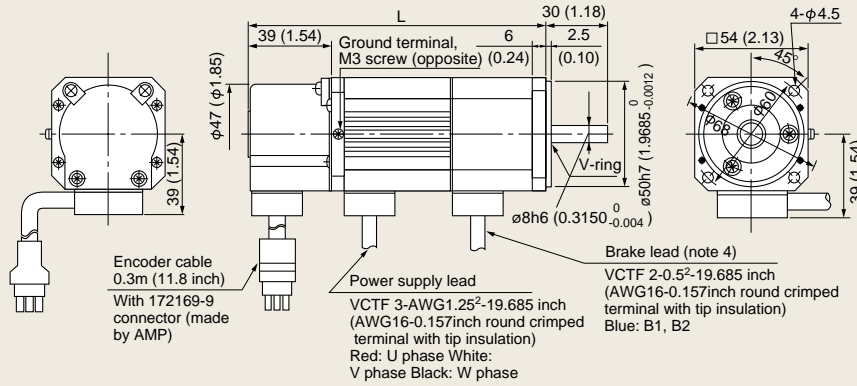

Model	Variable dimensions L
HA-FF053 (B)	106 (4.17) <141 (5.55)>
HA-FF13 (B)	123 (4.84) <158 (6.22)>

## ● HA-FF23 (B), HA-FF33 (B)

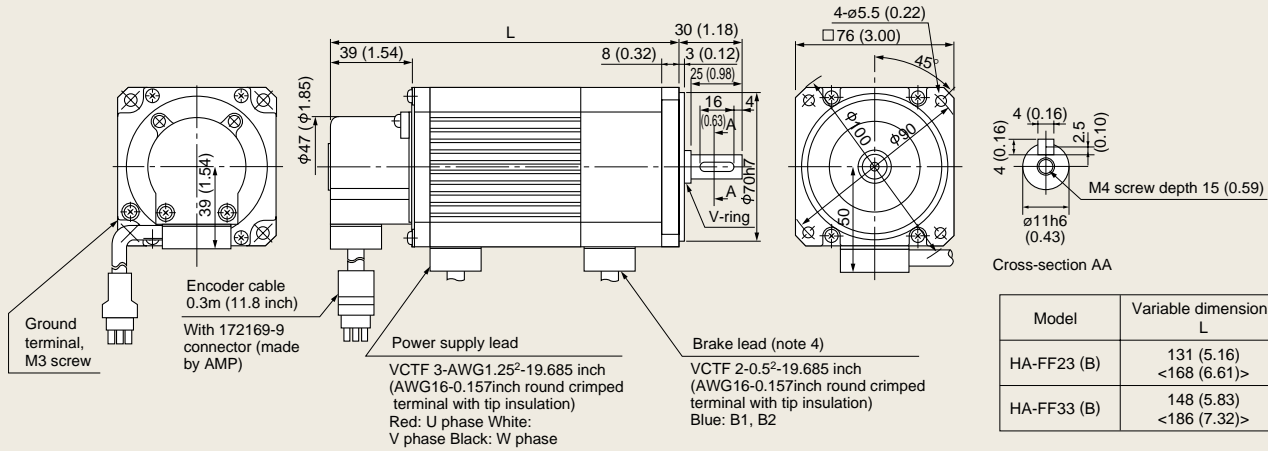

Model	Variable dimensions L
HA-FF23 (B)	131 (5.16) <168 (6.61)>
HA-FF33 (B)	148 (5.83) <186 (7.32)>

## ● HA-FF43 (B), HA-FF63 (B)

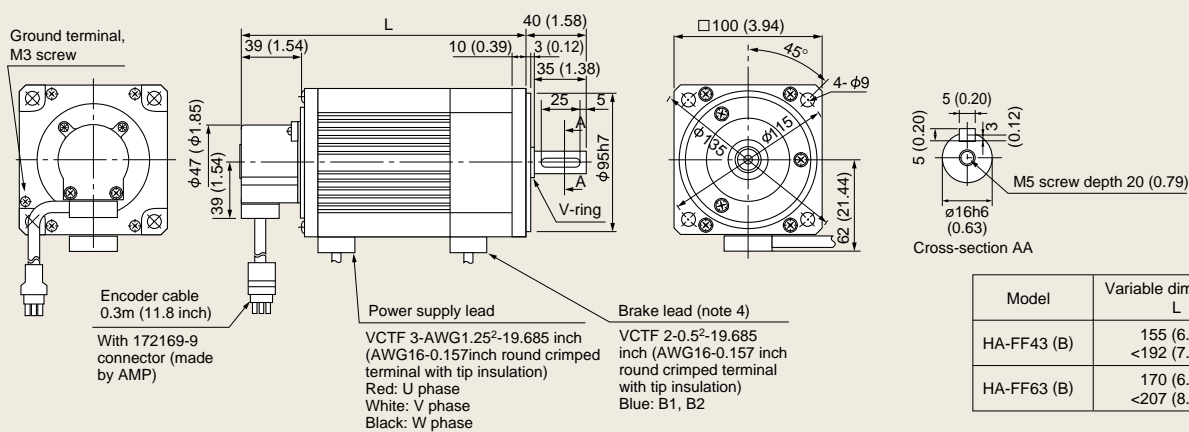

Model	Variable dimensions L
HA-FF43 (B)	155 (6.10) <192 (7.56)>
HA-FF63 (B)	170 (6.69) <207 (8.15)>

### Notes:

1. When mounting the servomotor horizontally we recommend encoder connector be mounted downward.
2. Use a friction coupling to fasten the load.
3. Dimensions inside < > are for models with electromagnetic brakes.
4. Only for models with electromagnetic brakes.
5. The inertial moment value in the table is the motor axis conversion value (motor+decelerator).

# External Dimensions

- HC-SF81 (B)
- HC-SF52 (B)~HC-SF152 (B)
- HC-SF53 (B)~HC-SF153 (B)

Unit: mm (inch)

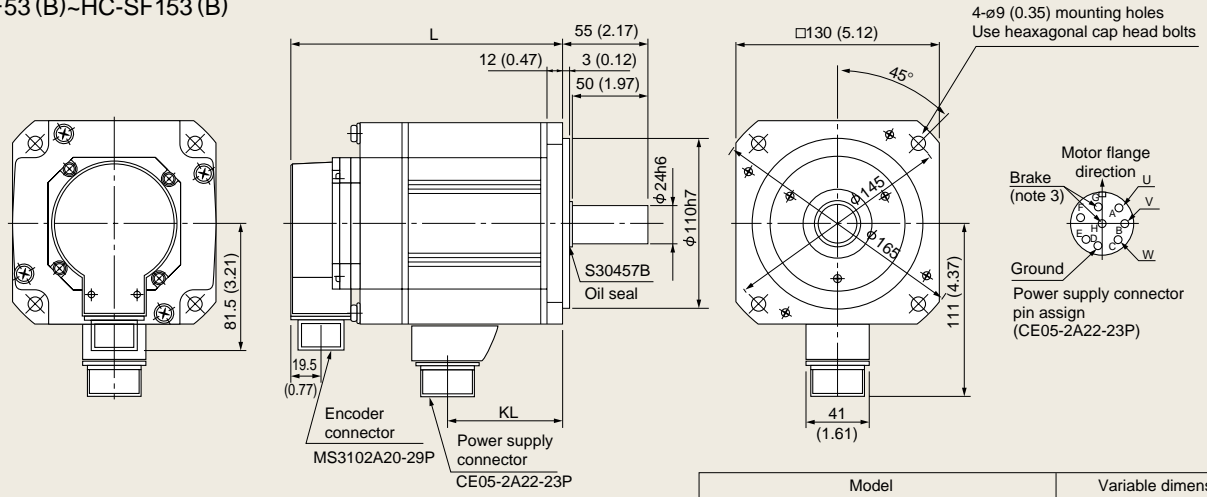

Model			Variable dimensions	
1000 r/min	2000 r/min	3000 r/min	L	KL
—	HC-SF52 (B)	HC-SF53 (B)	120 (4.72) <153 (6.03)>	51.5 (2.03)
—	HC-SF102 (B)	HC-SF103 (B)	145 (5.71) <178 (7.01)>	76.5 (3.01)
HC-SF81 (B)	HC-SF152 (B)	HC-SF153 (B)	170 (6.69) <203 (7.99)>	101.5 (4.00)

- HC-SF121 (B)~HC-SF301 (B)
- HC-SF202 (B)~HC-SF702 (B)
- HC-SF203 (B)~HC-SF353 (B)

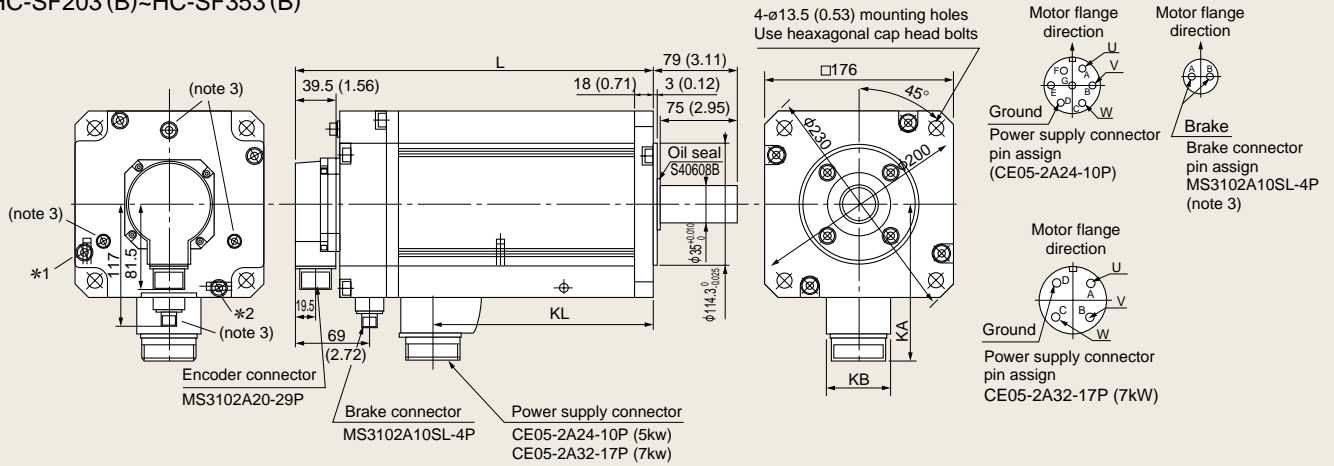

\*1, \*2 is the screw hole for the lifting bolts.  
The screw holes for the lifting bolts are only HC-SF702 (B).

Model			Variable dimensions			
1000 r/min	2000 r/min	3000 r/min	L	KL	KA	KB
HC-SF121 (B)	HC-SF202(B)	HC-SF203 (B)	145 (5.71) <193 (7.60)>	68.5 (2.70)	142 (5.60)	46 (1.81)
HC-SF201 (B)	HC-SF352 (B)	HC-SF353 (B)	187 (7.36) <235 (9.25)>	110.5 (4.35)	142 (5.60)	46 (1.81)
HC-SF301 (B)	HC-SF502 (B)	—	208 (8.19) <256 (10.08)>	131.5 (5.18)	142 (5.60)	46 (1.81)
—	HC-SF702 (B)	—	292 (7.56) <340 (13.39)>	210.5 (8.29)	150 (5.91)	58 (2.28)

- Notes:
1. Use a friction coupling to fasten the load.
  2. Dimensions inside < > are for models with electromagnetic brakes.
  3. Only for models with electromagnetic brakes.
  4. The inertial moment value in the table is the motor axis conversion value (motor+decelerator).

# External Dimensions

## ● HC-RF103 (B), HC-RF153 (B), HC-RF203 (B)

Unit: mm (inch)

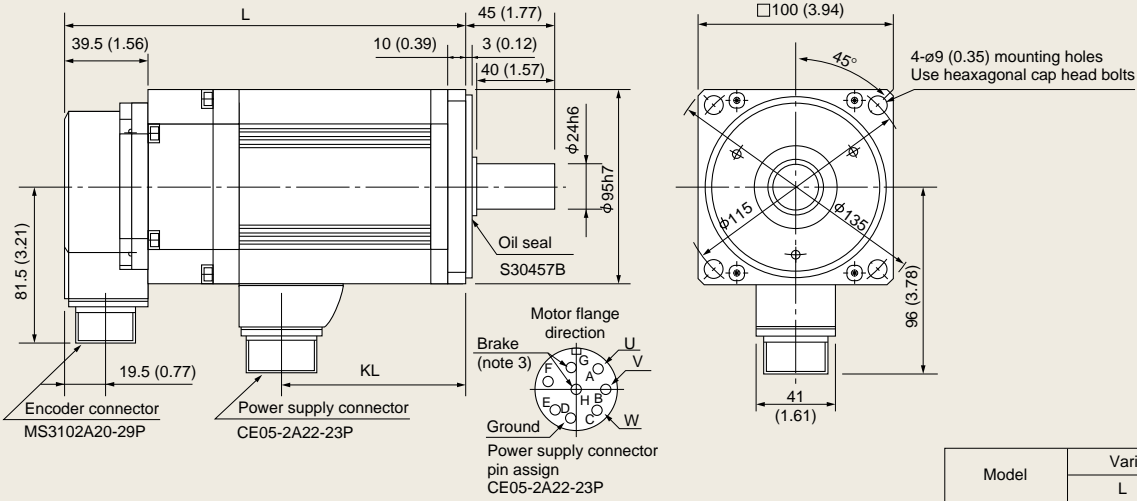

Model	Variable dimensions	
	L	KL
HC-RF103 (B)	147 (5.79) <185 (7.28)>	71 (2.80)
HC-RF153 (B)	172 (6.77) <210 (8.27)>	96 (3.78)
HC-RF203 (B)	197 (7.76) <235 (9.25)>	121 (4.76)

## ● HC-RF353 (B), HC-RF503 (B)

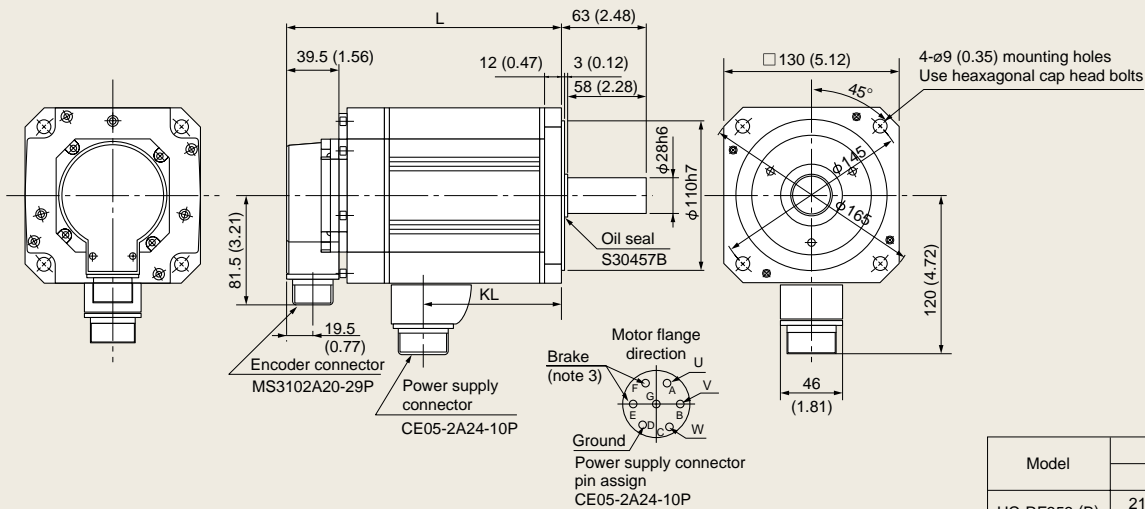

Model	Variable dimensions	
	L	KL
HC-RF353 (B)	217 (8.54) <254 (10.00)>	148 (5.83)
HC-RF503 (B)	274 (10.79) <311 (12.24)>	205 (8.07)

### Notes:

1. Use a friction coupling to fasten the load.
2. Dimensions inside < > are for models with electromagnetic brakes.
3. Only for models with electromagnetic brakes.

# External Dimensions

## ● HC-UF13 (B)

Unit: mm (inch)

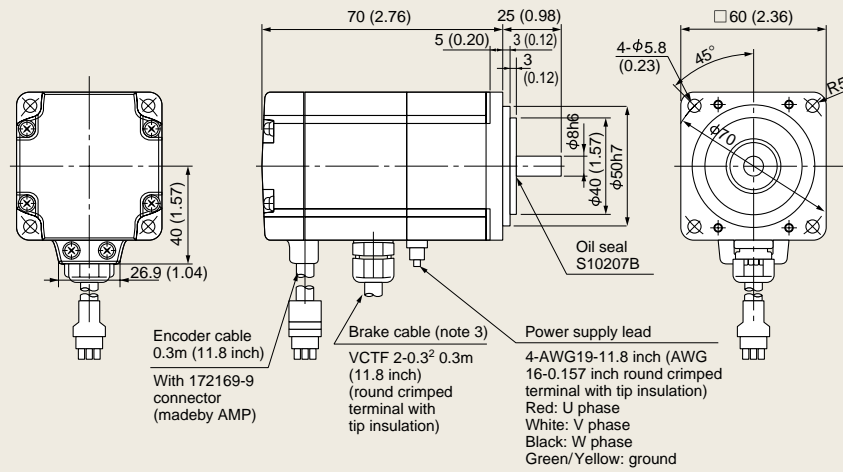

## ● HC-UF23 (B), HC-UF43 (B)

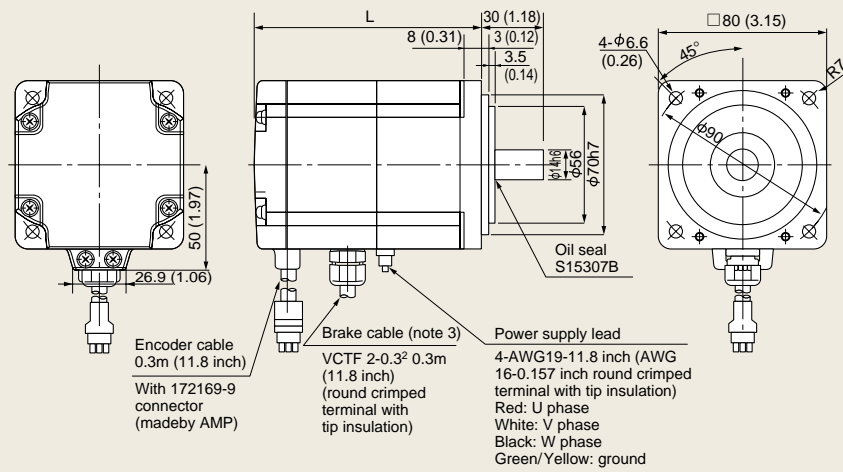

Model	Variable dimensions
	L
HC-UF23 (B)	75 (2.95) <109 (4.29)>
HC-UF43 (B)	90 (3.54) <124 (4.88)>

## ● HC-UF73 (B)

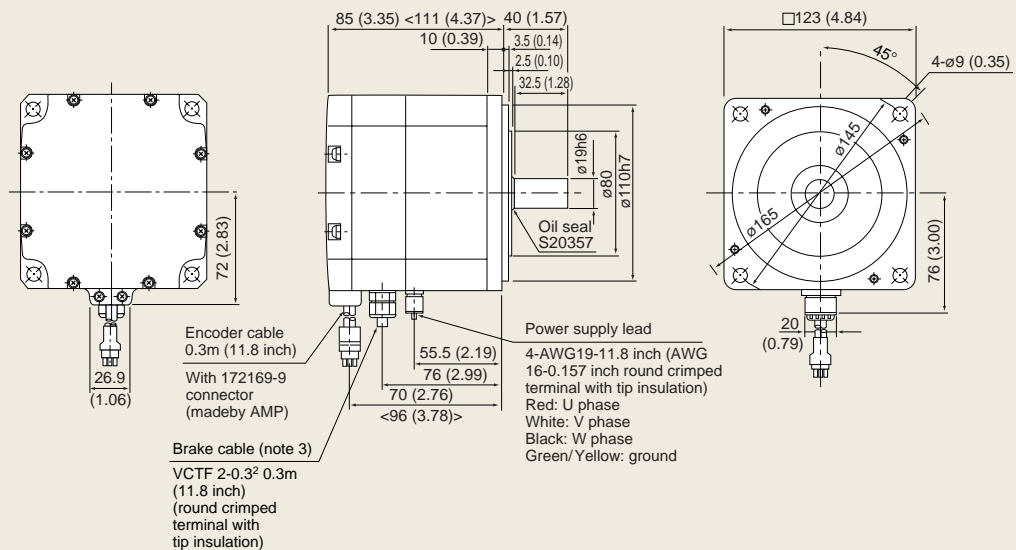

### Notes:

1. Use a friction coupling to fasten the load.
2. Dimensions inside < > are for models with electromagnetic brakes.
3. Only for models with electromagnetic brakes.

# External Dimensions

## ● HC-UF72 (B), HC-UF152 (B)

Unit: mm (inch)

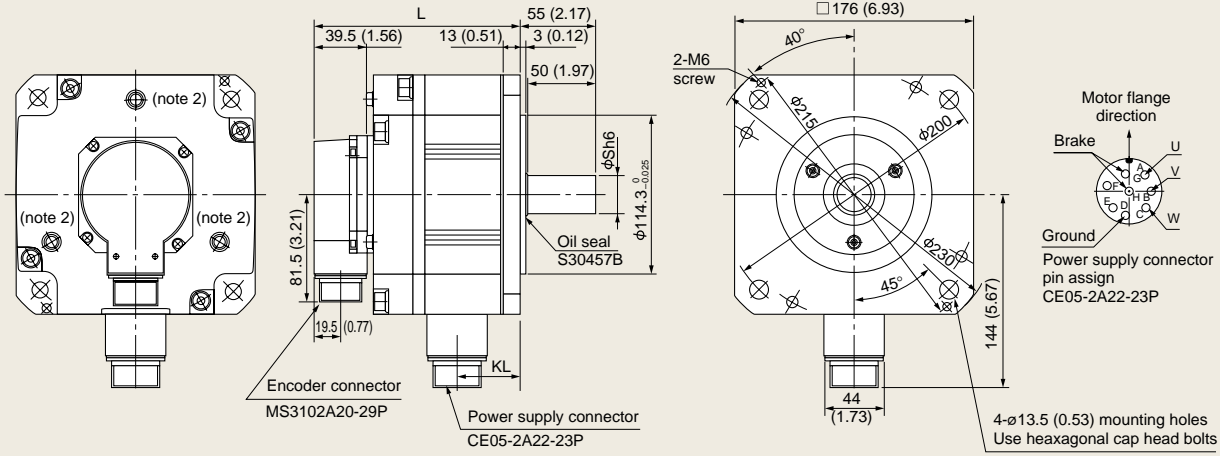

Model	Variable dimensions		
	L	KL	S
HC-UF72 (B)	110.5 (4.35) <144 (5.67)>	38 (1.50)	22 (0.87)
HC-UF152 (B)	120 (4.72) <153.5 (6.04)>	47.5 (1.87)	28 (1.10)

## ● HC-UF202 (B), HC-UF352 (B), HC-UF502 (B)

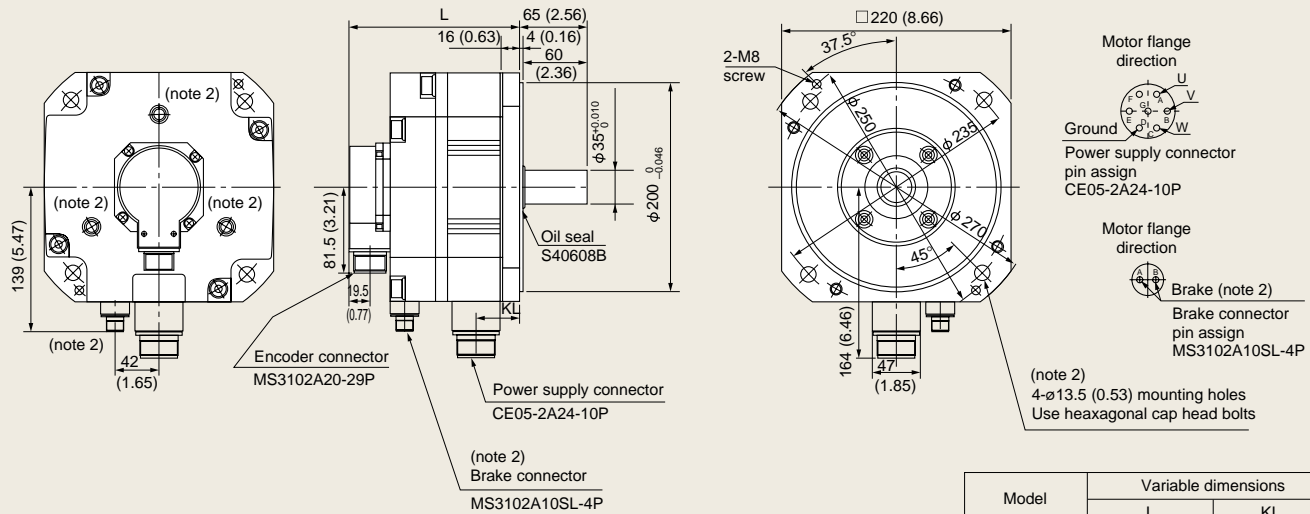

Model	Variable dimensions	
	L	KL
HC-UF202 (B)	118 (0.04) <161 (6.34)>	42.5 (1.67)
HC-UF352 (B)	142 (5.60) <185 (7.28)>	66.5 (2.62)
HC-UF502 (B)	166 (6.54) <209 (8.23)>	90.5 (3.56)

- Notes:
1. Use a friction coupling to fasten the load.
  2. Dimensions inside < > are for models with electromagnetic brakes.
  3. Only for models with electromagnetic brakes.



# External Dimensions

## ● HA-LH52~HA-LH502

Unit: mm (inch)

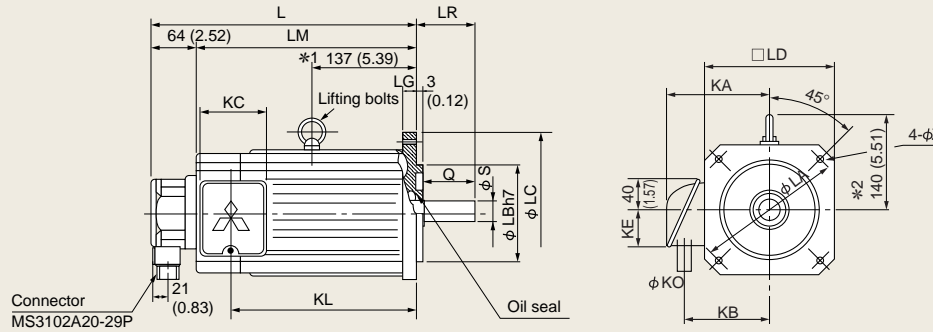

Model	Variable dimensions													Variable dimensions (axis end)				
	L	φLA	φLB	φLC	□LD	LG	LM	KA	KB	KC	φKD	KL	KE	φZ	LR	Q	φS	Oil seal
HA-LH52	204 (8.03)	145 (5.71)	110 (4.33)	165 (6.50)	130 (5.12)	12 (0.47)	140 (5.51)	104 (4.09)	84 (3.31)	80 (3.15)	22 (0.87)	117 (4.67)	40 (1.57)	9 (0.35)	55 (2.17)	50 (1.97)	24h6	S25408B
HA-LH102	244 (9.61)	145 (5.71)	110 (4.33)	165 (6.50)	130 (5.12)	12 (0.47)	180 (7.09)	104 (4.09)	84 (3.31)	80 (3.15)	22 (0.87)	157 (6.18)	40 (1.57)	9 (0.35)	55 (2.17)	50 (1.97)	24h6	S25408B
HA-LH152	294 (11.57)	145 (5.71)	110 (4.33)	165 (6.50)	130 (5.12)	12 (0.47)	230 (9.06)	104 (4.09)	84 (3.31)	80 (3.15)	22 (0.87)	207 (8.15)	40 (1.57)	9 (0.35)	55 (2.17)	50 (1.97)	24h6	S25408B
HA-LH202	259 (10.20)	200 (7.87)	114.3 (4.50)	230 (9.06)	170 (6.69)	18 (0.71)	195 (7.68)	124 (4.88)	104 (4.09)	80 (3.15)	22 (0.87)	171 (6.73)	40 (1.57)	13.5 (0.53)	79 (3.11)	—	35 <sup>+0.010</sup> <sub>0</sub>	S35508B
HA-LH302	299 (11.77)	200 (7.87)	114.3 (4.50)	230 (9.06)	170 (6.69)	18 (0.71)	235 (9.25)	124 (4.88)	104 (4.09)	80 (3.15)	22 (0.87)	211 (8.31)	40 (1.57)	13.5 (0.53)	79 (3.11)	—	35 <sup>+0.010</sup> <sub>0</sub>	S35508B
HA-LH502	329 (12.95)	215 (8.46)	180 (7.09)	250 (9.84)	200 (7.87)	20 (0.79)	265 (10.43)	150 (5.91)	123 (4.84)	93 (3.66)	27 (1.06)	245 (9.65)	62 (2.44)	14.5 (0.57)	85 (3.35)	80 (3.15)	42h6	S45628B

### Notes:

1. Install the connector in a downward direction which will give an anti-spray effect.
2. There is no axis terminal key. When coupling the load, use a friction joint.
3. Same dimensions with the absolute position sensor attached. Lifting bolts (M8) are used for the HA-LH502. Lifting bolt measurements (\*1 and \*2) are related only to HA-LH502.

## ● HA-LH702

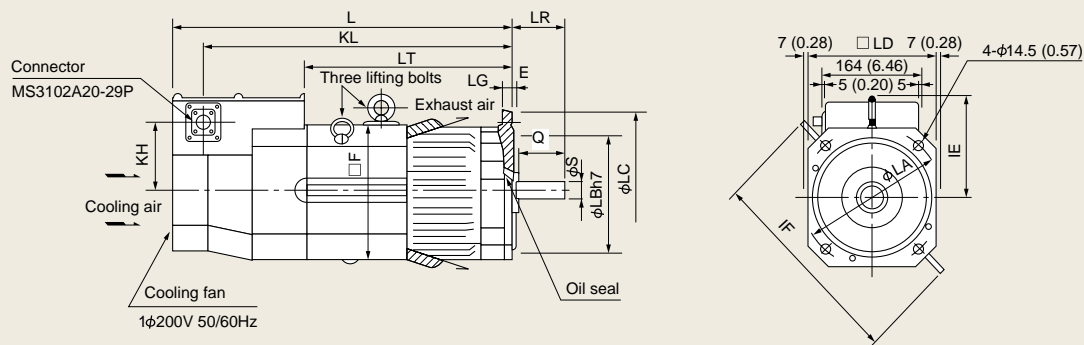

Model	Variable dimensions													Variable dimensions (axis end)				
	□F	L	LA	φLB	LC	□LD	LG	LT	KL	KH	IE	IF	Lifting bolts	E	LR	Q	φS	Oil seal
HA-LH702	208 (8.19)	459 (18.07)	215 (8.46)	180 (7.09)	250 (9.84)	204 (8.03)	20 (0.79)	246 (9.69)	408 (16.06)	102 (4.02)	152 (5.98)	317 (12.48)	M10	3 (0.12)	85 (3.35)	80 (3.15)	42h6	S45629B

### Notes:

1. Maintain a minimum distance of 50mm (1.97 inch) between the motor intake and the wall.
2. When using with the lifting bolt removed, the screw holes should be covered with a bolt whose diameter is a maximum 1.5 times longer than that of the lifting bolt.
3. Use a friction coupling to fasten the load.
4. Outlet wiring from the terminal box consists of 5 wires: UVW and 2 fan wires.
5. The motor with absolute encoder is also the same size.

# List of Servomotor Combinations

Servomotors	Series	Ultra-low inertia/Low capacity					Low inertia/Low capacity					Medium inertia/Medium capacity								
	Rated speed (maximum) (r/min)	3000 (4500)					3000 (4000)					1000 (1500: 0.85kW 1200: 1.2~3kW)			2000 (3000: 0.5~1.5kW 2500: 2, 3.5kW 2000: 5, 7kW~)					
	Model	HC-MF					HA-FF					HC-SF								
	053	13	23	43	73	053	13	23	33	43	63	81	121	201	301	52	102	152	202	
Corresponding servo-amp models	MR-H10□N						○	○												
	MR-H20□N	●	●						○											
	MR-H40□N			●						○	○									
	MR-H60□N				●							○					○			
	MR-H100□N					●							○					○		
	MR-H200□N													○	○				○	○
	MR-H350□N															○				
	MR-H500□N																			
	MR-H700□N																			
	MR-H11K□N																			
	MR-H15K□N																			
	MR-H22K□N																			

Notes: 1. Empty circles indicate compatibility with the listed servo-amp.  
2. Solid circles indicate the combination with a MR-J2 is different. Take note that the combinations with the MR-J2 are different.

## Cautions Concerning Use

### To ensure safe use

- To ensure the safe and proper use of the product, we ask that you read the instruction manual prior to its use.
- These products are not designed or manufactured for use in machinery and systems where people's safety is at stake.
- When considering the product for use in such special applications as equipment or systems employed in passenger transportation, medicine, aerospace, nuclear power generation, or underwater relays, please contact our sales representative.
- This product has been manufactured to the most rigorous quality standards. However, we ask that you employ safety devices when using the product in equipment in which any failure on its part can be expected to cause a serious accident or loss.

### Cautions concerning use

#### Transport and installation of motor

- Protect the motor from impact during handling. When installing the pulley or coupling, do not hammer on the shaft. Impact can damage the encoder. Use a pulley puller when taking off the pulley.



### Installation

- Avoid installation in an environment in which oil mist, dust, etc. are in the air. When using in such an environment, enclose the servo-amp in an airtight panel. Protect the motor by furnishing a cover for it or taking similar measures.
- Mount the amp vertically on a wall.
- When installing multiple amps inside an airtight panel, leave at least 10 millimeters between amps. Leave at least 40 millimeters of space above and below the amp. When installing multiple amps, leave 100 millimeters of space or install a fan to ensure that heat is not trapped inside the panel.

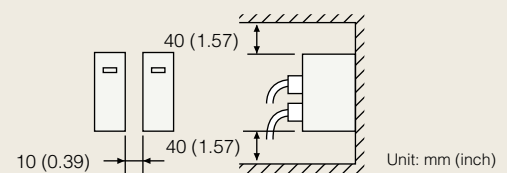

- While installing a single motor, the motor can be installed horizontally or vertically. When installing vertical (upside the shaft) take measures on the machine side to ensure that oil from the gear box does not get into the motor.
- The optional regeneration unit becomes hot (temperature rise of 100°C or more) with frequent use. Do not install within flammable objects or objects subject to thermal deformation. Take care to ensure that electric wires do not come into contact with the main unit.

## List of Servo Motor Combinations

Medium inertia/Medium capacity							Low inertia/Medium capacity					Flat low capacity/Medium capacity					Low inertia / High capacity							
2000 (3000: 0.5~1.5kW) (2500: 2, 3.5kW) (2000: 5, 7kW~)			3000 (3000)				3000 (4500)					2000 (3000: 0.75~2kW) (2500: 3.5, 5kW)			3000 (4500)		2000 (2000)							
HC-SF							HC-RF					HC-UF					HA-LH							
352	502	702	53	103	153	203	353	103	153	203	353	503	72	152	202	352	502	13	23	43	11K2	15K2	22K2	
																		○						
																			●					
			○																	●				
				○									●											
					○	○		○	○						○									
	○						○				○				○									
		○										○	○			○	○							
			○																					
																						○		
																							○	
																								○

### Wiring

- A power supply to the amp's output terminal (U, V, W) will damage the amp. Before switching the power on, perform thorough wiring and sequence checks to ensure that there are no wiring errors, etc.
- Connecting wall out-let onto the motor's input terminal (U, V, W) will burn out the motor. Connect the motor to the amp's output terminal (U, V, W).
- Match the phase of the motor input terminal (U, V, W) to the output terminal (U, V, W) before connecting. If they are not the same, motor control cannot be performed.
- In position control mode, connect the stroke end signal (LSP, LSN) to the common terminal (SG). If it is not connected, the motor will not rotate.

### Factory settings

- All possible motor and amp combinations are predetermined. Confirm the model of the motor and amp to be used before installation.
- Position, speed, and torque control modes are selected with parameter 0. The factory setting is position control mode. For speed operation, change this setting.
- When using the optional regeneration unit, change parameter 0. The factory setting is for no optional regeneration unit. Therefore, if this parameter is not changed, the unit's capacity will not be increased.

### Operation

- When a magnetic contactor (MC) is installed on the amp's primary side, do not perform frequent starts and stops with the MC. Doing so could cause the amp to fail.

- When an error occurs, the amp's safety features are activated, halting output, and the dynamic brake instantly stops the motor. If free run is required, contact Mitsubishi about solutions involving servo-amps where the dynamic brake is not activated.
- When using a motor with an electromagnetic brake, do not apply the brake when the servo is on. Doing so could cause an amp overload or shorten brake life. Apply the brake when the servo is off.

### Cautions concerning model selection

- Select a motor with a rated torque above the continuous effective load torque.
- Design the operation pattern so that positioning can be completed, taking into account the setting time (ts).

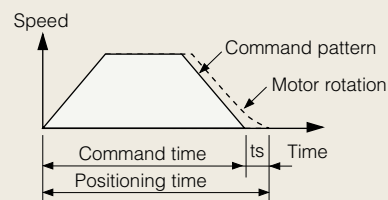

- Use the unit with the load's inertia set below the recommended load/inertia ratio of the motor being used. If it is too large, desired performance may not be attainable.



### **Safety Warning**

To ensure proper use of the products listed in this catalog,  
please be sure to read the instruction manual prior to use.

 **mitsubishi electric corporation**  
HEAD OFFICE: MITSUBISHI DENKI BLDG., 2-2-3, MARUNOUCHI, CHIYODA-KU, TOKYO 100-8310, JAPAN

---