

OPERATING INSTRUCTIONS

ZF Electronic Control Unit ERM



6057 758 101a

Subject to alterations in design

Copyright by ZF

These operating instructions are protected by copyright. Any reproduction and dissemination in whatever form – also in adapted, paraphrased or extracted form – in particular as a reprint, photomechanical or electronic reproduction or as a storage in data-processing equipment or data networks without approval by the holder of the copyright is prohibited and will be prosecuted under civil and criminal law.

Printed in Germany

Edition: 03.2001

Companies repairing ZF units are responsible for their own work safety.

To avoid injury to personnel and damage to products, all safety regulations and legal requirements which apply to repair and maintenance work must be adhered to. Before starting work, mechanics must familiarize themselves with these regulations.

Personnel required to carry out repairs on ZF products must receive appropriate training in advance. It is the responsibility of each company to ensure that their repair staff is properly trained.

The following safety instructions appear in this manual:

NOTE

Refers to special processes, techniques, data, use of auxiliary equipment, etc.

CAUTION

This is used when incorrect, unprofessional working practices could damage the product.



DANGER

This is used when lack of care could lead to personal injury or death.

General Information

Read this manual carefully before starting any tests or repair work.

CAUTION

Pictures, drawings and components do not always represent the original object, but are used to illustrate working procedures.

Pictures, drawings and components are not to scale.

Conclusions about size and weight should not be drawn (even within a complete illustration). Always follow the working steps as described in the text.

After completion of repair work and testing, skilled staff must satisfy themselves that the product is functioning correctly.

1	Technical data	6			
1.1	Technical data, installation dimensions	6	3.4	Operating mode “controlled with Ø calculation” .	30
1.2	Circuit board removal and installation	8	3.4.1	Function diagram	30
1.3	Circuit board configuration	10	3.4.2	Pin assignment	31
1.4	Pin assignment	12	3.4.3	Technical instructions	32
1.5	Summary of pin assignment	14	3.4.4	Startup	33
2	Description	16	3.5	Operating mode “closed-loop control”	34
2.1	General configuration	16	3.5.1	Function diagram	34
2.2	Coding clutch / brake	18	3.5.2	Pin assignment	35
2.3	Controller for transfer function	19	3.5.3	Technical instructions	36
			3.5.4	Startup	36
3	Operating modes	20	3.6	Additional functions max-power / zero-power ...	37
3.1	Operating mode “open loop (current)”	20	4	Identification and causes of failure /	
3.1.1	Function diagram	20		corrective action	38
3.1.2	Pin assignment	21			
3.1.3	Technical instructions	22			
3.1.4	Startup	22			
3.2	Operating mode “open loop (torque)”	23			
3.2.1	Function diagram	23			
3.2.2	Pin assignment	24			
3.2.3	Technical instructions	25			
3.2.4	Startup	25			
3.3	Operating mode “controlled with Ø sensing”	26			
3.3.1	Function diagram	26			
3.3.2	Pin assignment	27			
3.3.3	Technical instructions	28			
3.3.4	Startup	28			

1 Technical data

1.1 Technical data, installation dimensions

Nominal direct voltage for ZF hysteresis clutches and brakes at nominal torque and a coil temperature of 120 °C:	30 V DC	Ambient temperature:	0 to +50 °C
Permissible residual ripple:	1.5 V	Storage temperature:	−30 to +70 °C
Operating voltage range:	24 V to 36 V DC	Humidity class:	DIN IEC 68, part 2–30
Open circuit power consumption:	< 150 mA	Safety class according to DIN 40 050:	IP 30
Maximum current input: (depending on unit size)	2.8 A	Rack:	19" 7 TE plug-in module
Fuse:	fine-wire fuse 4A medium time-lag fuse	Connection:	18-pin pull-off screw-type terminal (within the scope of supply)
Voltage output:	10 V = +/- 0.8 V 20 mA ($R_{a \min} = 500 \Omega$)	Weight:	0.6 kg
Frequency input:	input resistance $R_E \geq 3.3 \text{ k}\Omega$	NOTE	
Switching threshold "low" to "high"	> 11.5 V DC	The screw-type terminal block is not suitable for bus assembly. Make sure that connecting cables are long enough or that the screw-type terminal block on the rear of the assembly rack is accessible.	
Switching threshold "high" to "low"	< 4.0 V DC		

Installation dimensions

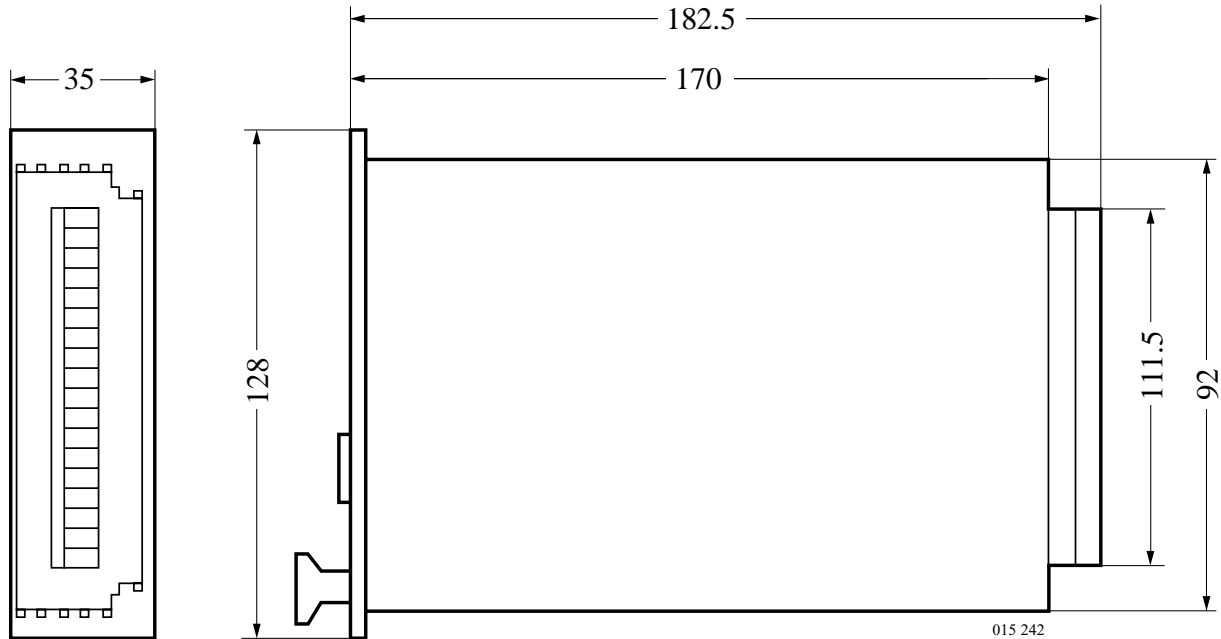

1.2 Circuit board removal and installation

Removal:

1. Switch off operating voltage.

CAUTION

If the operating voltage is not switched off, product and system can be damaged.

2. Remove terminal strip (2) from plug connector (3).
3. Remove screws (1 + 4).
4. Carefully pull board out of the rack without tilting.

Installation:

1. Carefully insert board into rack, guiding slot without tilting.
2. Tighten screws (1 + 4) so that the cooling attachment on the board contacts the metal rack and thus ensures optimum heat dissipation.

NOTE

Do not exceed permissible tightening torque to avoid board damage.

3. Make sure that operating voltage is switched off.

CAUTION

If the operating voltage is not switched off, product and system can be damaged.

4. Introduce terminal strip (2) into plug connector (3).

CAUTION

Contacts must not be damaged, otherwise perfect functioning of the system is not ensured.

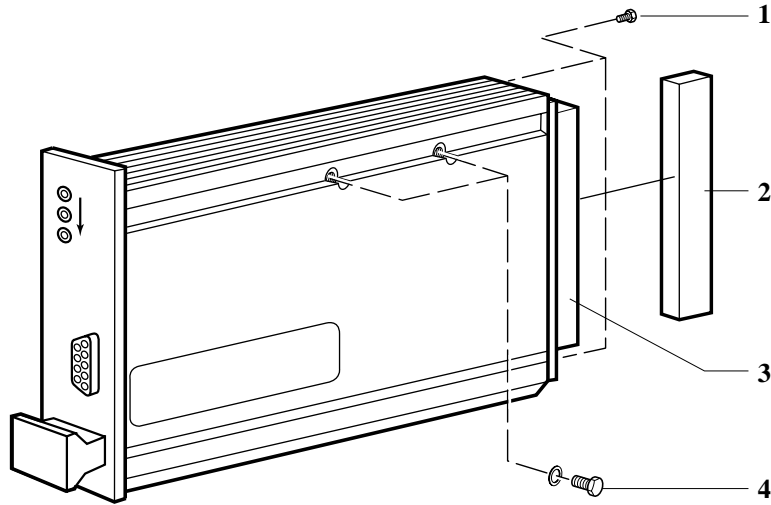

015 239

1.3 Circuit board configuration

Designation	Function
LED (1) “Power”	Supply voltage is applied and ERM program is ready.
LED (2) “Feedb.”	Closed-loop control operating mode, i.e. DIL switch position 5 and 6 = “1”.
LED (3) “Ø-Contr.”	<ul style="list-style-type: none"> • Ø sensing operation, DIL switch position 5 = “1” and 6 = “0” or • Ø calculation operation, DIL switch position 5 = “0” and 6 = “1”. • LED “Ø-Contr.” flashes, if the setting procedure has not been carried out in the operating mode Ø calculation or Ø sensing.
Connection for diagnostic unit	Diagnostic connector for ZF MOBiDIG tester K-cable, acc. to ISO 9141
Jumper	For function selection. e.g. feed rate interruption, emergency brake
Fuse	Fine-wire fuse 4 A, medium time-lag fuse
DIL switches	Setting of various operating modes and unit sizes
Program memory	Includes microprocessor operating program
Data memory	Contains operating parameters
Terminal strip	18-pin

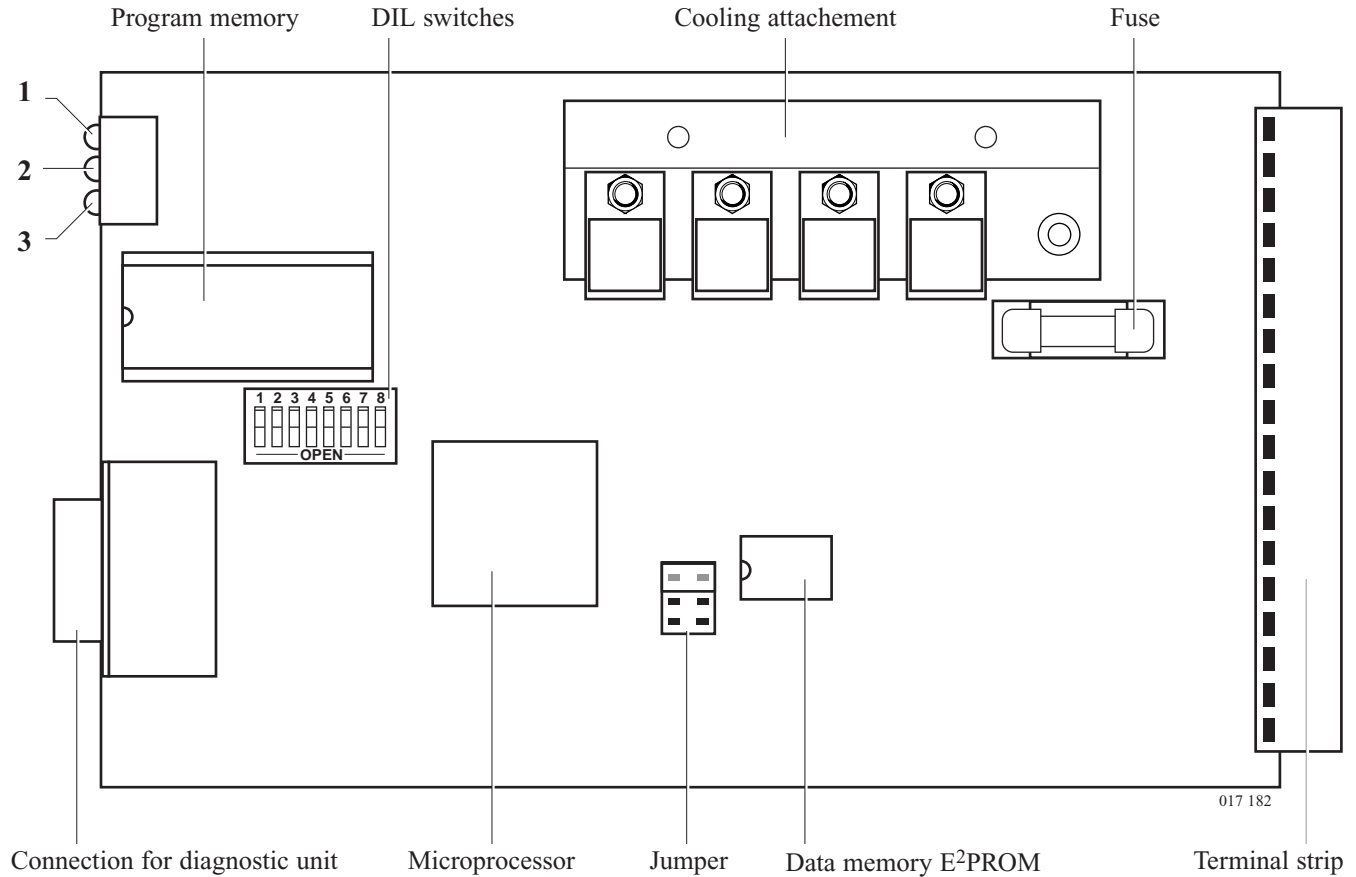

1.4 Pin assignment

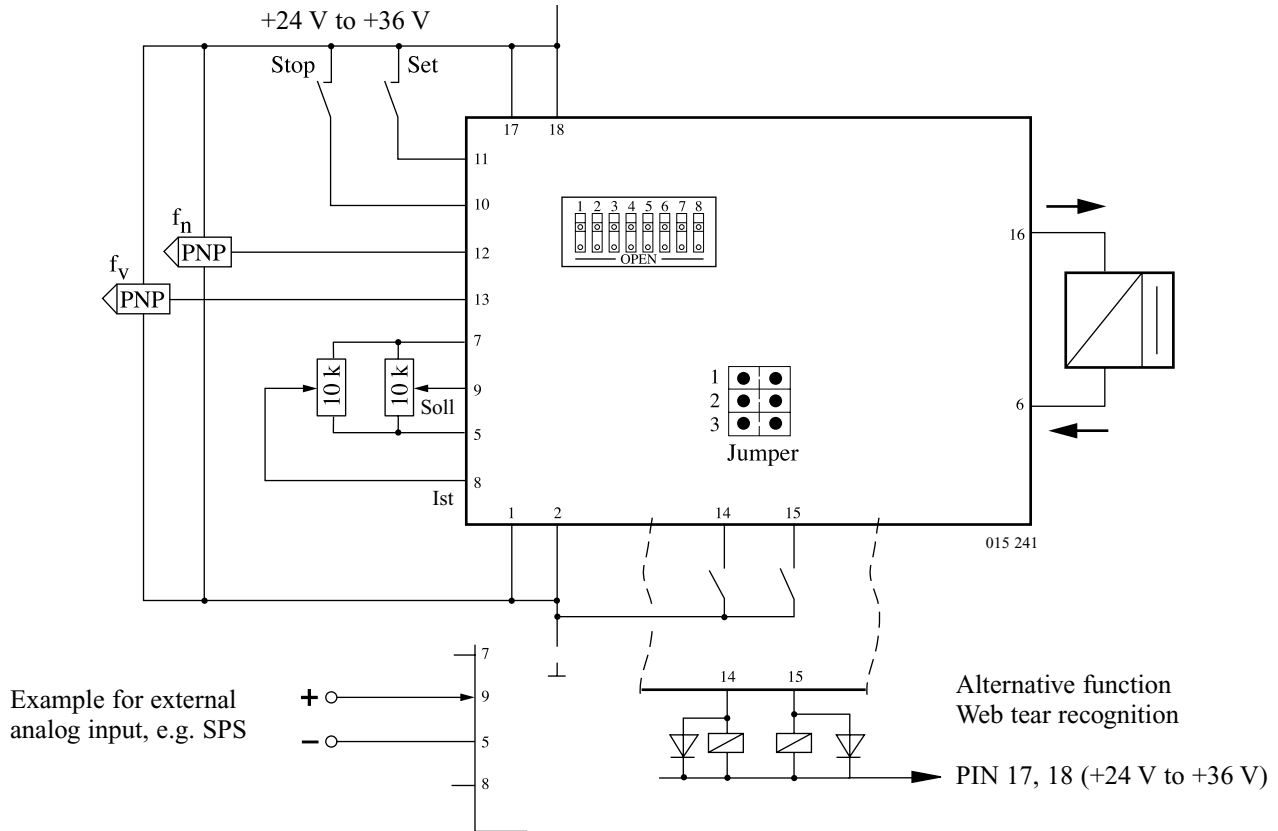

NOTE

The electronic control unit does not require the potentiometer to fulfill any particular requirements. However, mechanical requirements regarding installation need to be considered.

Recommendations for potentiometer:

Resistance value: 1 kΩ - 47 kΩ

Type: magneto-resistive potentiometer, for voltage input nom. value also wire potentiometer can be used.

Jumper-Position:

Appropriate function is activated by inserting a jumper.

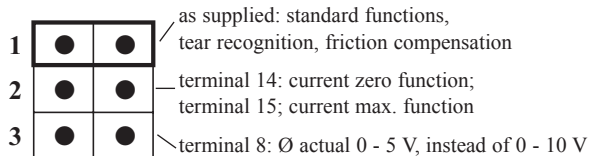

NOTE

Pos. 1 and 2 must never be connected simultaneously.

1.5 Summary of pin assignment

<i>PIN</i>	<i>Function</i>	<i>PIN</i>	<i>Function</i>
1	ground (-)	9	voltage input, nominal value (0 to +10 V) input resistance $R_i = 200 \text{ k}\Omega$; Input may also be supplied by external analog sources, provided the voltage refers to ground (PIN 5) and the max. value does not exceed +10 V.
2	ground (-)	10	digital input "stop" input resistance $4.7 \text{ k}\Omega$; input current 5 to 8 mA;* $U_{\text{max}} = \text{operating voltage}$ Function is maintained as long as the signal is on.
3	no assignment	11	digital input "set" (push-button) input resistance $4.7 \text{ k}\Omega$; input current 5 to 8 mA;* $U_{\text{max}} = \text{operating voltage}$
4	no assignment	12	frequency input - f_n (roller speed) frequency 3 to 1000 Hz; input resistance $3.3 \text{ k}\Omega$ pulse $\geq 0.5 \text{ ms}$, interpulse period $\geq 0.5 \text{ ms}$ input resistance $3.3 \text{ k}\Omega$
5	analog ground		
6	current return cable (measurement input) clutch / brake max. 2.55 A (depending on unit size)		
7	voltage output 10 V \pm 0.8 V DC max. load 20 mA; load impedance $R_{a \text{ min}} = 500 \Omega$		
8	voltage input, actual value (0 to +10 V) input resistance $R_i = 200 \text{ k}\Omega$; Input may also be supplied by external analog sources, provided the voltage refers to ground (PIN 5) and the max. value does not exceed +10 V.		

PIN Function

- 13 frequency input - f_v (feedrate)**
 frequency 3 to 1000 Hz;
 input resistance 3.3 k Ω
 pulse \geq 0.5 ms, interpulse period \geq 0.5 ms
 input resistance 3.3 k Ω
- 14 output roller speed**
 output voltage 24 V DC;
 max. load 50 mA;
 max. load impedance 10 k Ω ;
 A suppressor diode must be used with inductive load
 (no varistor!)
input current - zero
 load current 1 to 2 mA;*
 For functions consult relevant operation mode.
 Function is maintained as long as the signal is on.
- 15 output feedrate**
 output voltage 24 V DC;
 max. load 50 mA;
 max. load impedance 10 k Ω ;
 A suppressor diode must be used with inductive load
 (no varistor!)
input current - max.
 load current 1 to 2 mA;*
 For functions consult relevant operation mode.
 Function is maintained as long as the signal is on.

PIN Function

- 16 current output clutch / brake**
 max. 2.55 A (depending on unit size)
NOTE: Limit for EBU 2000!
- 17 voltage supply +24 V to +36 V**
 max. current 2.8 A (depending on unit size)
- 18 voltage supply +24 V to +36 V**
 max. current 2.8 A (depending on unit size)

*** NOTE**

Gold-plated contacts are recommended for pushbutton, switch and relays.

2. Description

2.1 General configuration

The ZF electronic control unit ERM can control ZF hysteresis clutches and brakes in different operating modes, as required by the application.

The ERM is controlled by a microprocessor and features programming, operation and diagnosis interfaces.

The ERM is designed for optimum supply of the ZF hysteresis clutches EKU and the ZF hysteresis brakes EBU. Controlled operating modes with size coding are less suitable for performance optimized brake range.

The DIL switches enable the following operating modes to be set:

- **Operating mode: “open-loop control (current)”**
This operating mode is set by the manufacturer, i.e. it is not necessary to change the DIL switch positions. Current is set and kept constant in accordance with the nominal value input.

Operating mode “open-loop control (current)”								
1	2	3	4	5	6	7	8	DIL switch
0	0	0	0	0	0	0	0	as supplied

- **Operating mode “open-loop control (torque)”**
The DIL switches must be set to suit unit size (Y Y Y Y) (see page 18).
Torque is set and kept constant in accordance with the nominal value input.

Operating mode “open-loop control (torque)”								
1	2	3	4	5	6	7	8	DIL switch
Y	Y	Y	Y	0	0	.	.	Unit size - coding (characteristic)

- **Operating mode “controlled with Ø sensing”**
The DIL switches must be set to suit unit size (Y Y Y Y) (see page 18).
Setting procedure:
 - sense maximum roller Ø
 - push set key
 - release set key
(reference value for max. Ø is accepted).

NOTE

Data are stored in non-volatile memory; data are not erased when the supply voltage is switched off.

The reference value for the max. \emptyset is not erased when the supply voltage is switched off. It can therefore be used when the ERM is fitted, i.e. it can be stored in E²PROM.

The stored reference value is deleted when another operating mode is selected (“open-loop control” or “closed loop control”).

Production speed and nominal traction may be altered even during operation.

Operating mode “controlled with \emptyset sensing”								DIL switch
1	2	3	4	5	6	7	8	Unit size - coding (characteristic)
Y	Y	Y	Y	1	0	.	.	

- **Operating mode: “controlled with \emptyset calculation”**

The DIL switches must be set to suit unit size (Y Y Y Y) (see page 18).

Setting procedure:

- approach maximum roller \emptyset
- push set key when production speed is reached

NOTE

If a frequency < 3 Hz is already reached during a setting procedure, no reference values will be transferred (LED 3 continues flashing). Frequency range 3 - 1000 Hz.

Stored reference values are deleted when another operating mode is selected (“open-loop control” or “closed loop control”).

- release set key (reference values for max. \emptyset is accepted).

Production speed and nominal traction may be altered even during operation.

Operating mode “controlled with \emptyset calculation”								DIL switch
1	2	3	4	5	6	7	8	Unit size - coding (characteristic)
Y	Y	Y	Y	0	1	.	.	

- Operating mode “closed-loop control”**

The DIL switches must be set to suit unit size (Y Y Y Y) (see page 18).

PD, PI and PID are available for position-and-force closed-loop control.

The I portion can be blocked by stop input. Thus, the last controlled torque is maintained when the unit is stopped.

Operating mode “closed-loop control”								
1	2	3	4	5	6	7	8	DIL switch
Y	Y	Y	Y	1	1	0	0	PD for position control
Y	Y	Y	Y	1	1	1	0	PI for force control e.g. with mech. compensator
Y	Y	Y	Y	1	1	1	1	PID for force control e.g. with no-travel tension sensor or freely programmable
Y	Y	Y	Y	1	1	0	1	PID for position or force control

Coding DIL switch								Type	nomi- nal current [A]	nomi- nal torque [Nm]
1	2	3	4	5	6	7	8			
1	0	0	0					EKU 0.3	0.9	0.4
0	1	0	0					EKU 1	1.3	1.0
1	1	0	0					EKU 3	1.5	3.0
0	0	1	0					EKU 10	1.8	12.0
1	0	1	0					EBU 0.1	0.4	0.15
0	1	1	0					EBU 0,3	0.75	0.4
1	1	1	0					EBU 1	1.25	1.1
0	0	0	1					EBU 3	1.25	3.3
1	0	0	1					EBU 10	1.5	12.0
0	1	0	1					EBU 30	2.2	39.0
1	0	0	1					EBU 60 G	1.5	82.0
0	1	0	1					EBU 200 G	2.2	268.0
1	1	0	1					EBU 250/1	1.1	0.6
0	0	1	1					EBU 500/3	1.4	2.5
1	0	1	1					EBU 1000/10	1.9	9.0
0	1	1	1					EBU 2000/30	2.7	26.0
0	0	1	1					EBU 500/30G	1.4	25.0
1	0	1	1					EBU 1000/100G	1.9	90.0
0	1	1	1					EBU 2000/300G	2.7	260.0
0	1	1	1					EBU 2000/600G	2.7	520.0

2.2 Coding clutch / brake

NOTE

With DIL switches 1-4, the ERM control unit can be set to the corresponding clutch or brake.

2.3 Controller for transfer function

PD for position control

Coding DIL switch							
1	2	3	4	5	6	7	8
						0	0

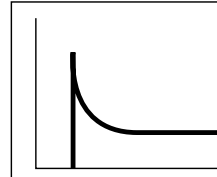

PI for force control
e.g. mech. compensator

Coding DIL switch							
1	2	3	4	5	6	7	8
						1	0

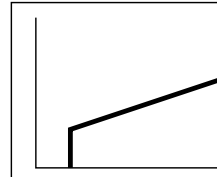

PI for force control
e.g. no-travel tension sensor

Coding DIL switch							
1	2	3	4	5	6	7	8
						1	1

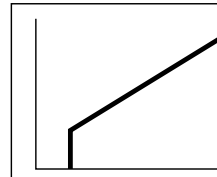

PID for position or
force control

Coding DIL switch							
1	2	3	4	5	6	7	8
						0	1

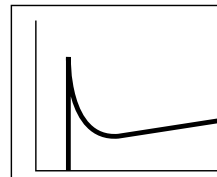

017 601

3. Operating modes

3.1 Operating mode “open-loop (current)”

3.1.1 Function diagram

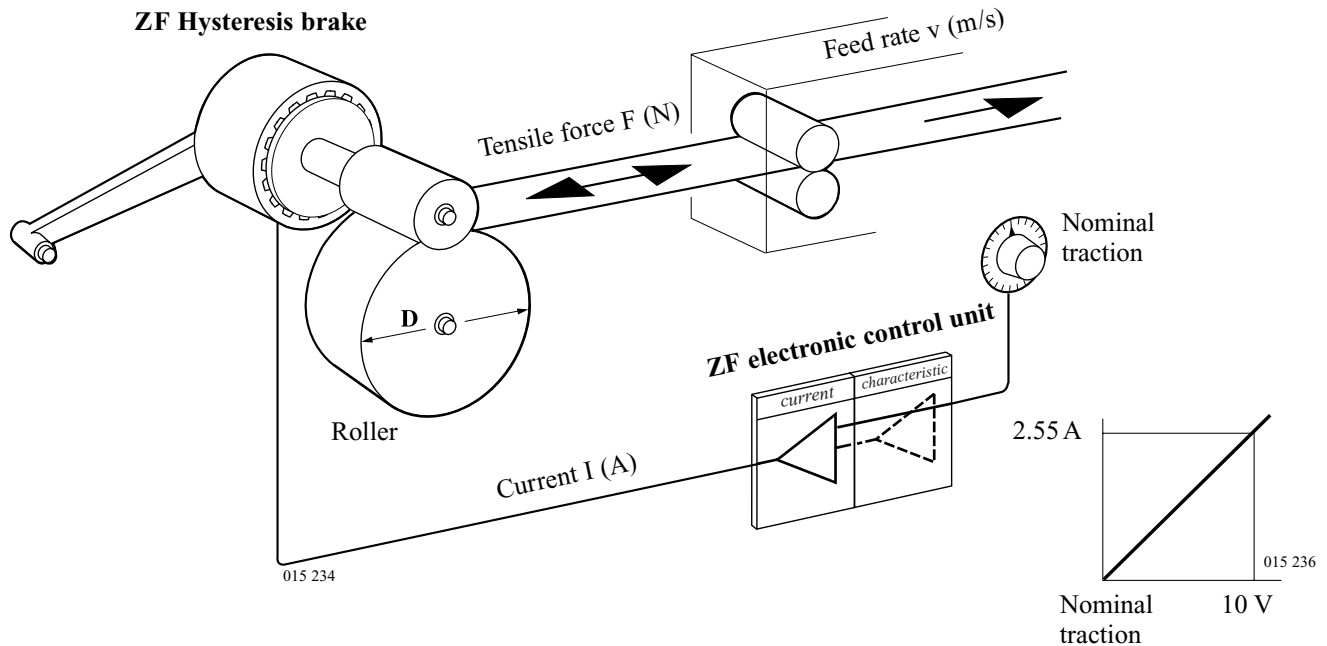

3.1.2 Pin assignment

Designation	PIN connection
Voltage supply plus 24 - 36 V	17, 18
Voltage supply ground	1, 2
Nominal traction sensor	7, 5, grinder 9
Hysteresis brake	16, 6

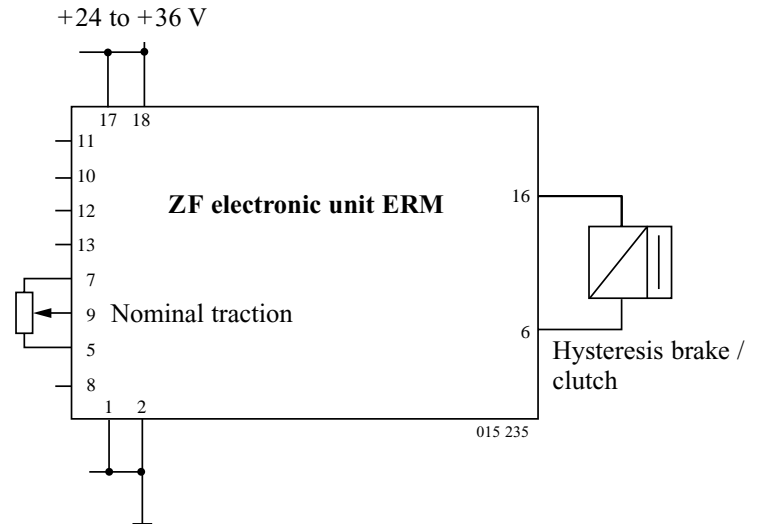

3.1.3 Technical instructions

LED: "Power" ON

Control: Current is set by the electronic system in accordance with the nominal value input.

DIL switch setting:

DIL switch setting

DIL switches							
1	2	3	4	5	6	7	8
0	0	0	0	0	0	0	0

Jumper position: Jumper position "2" (see 1.4, page 13) can activate further functions.

3.1.4 Startup

1. The electronic control unit is disconnected.
2. Make sure that voltage is within the range given under "1. Technical Data"! (see page 6)
3. Check polarity (plus / minus)!

CAUTION

Unpermitted voltage and polarity may damage the installation!

4. Switch off operating voltage!
5. Connect the ERM!
6. Switch on operating voltage!
"Power" LED must light up.
7. The installation is ready for operation.

NOTE

Should the installation not function properly, see "4. Identification and causes of failure / corrective action" (see page 38)!

3.2 Operating mode “open-loop control (torque)”

3.2.1 Function diagram

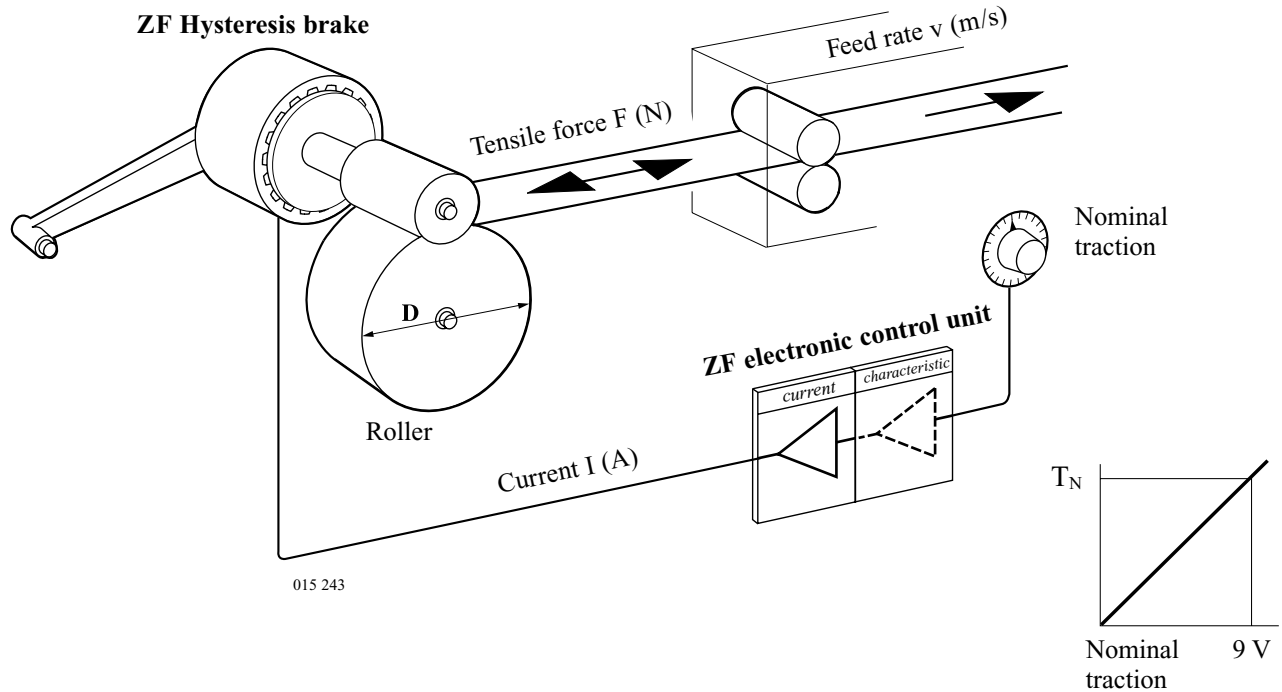

015 243

3.2.2 Pin assignment

Designation	PIN connection
Voltage supply plus 24 - 36 V	17, 18
Voltage supply ground	1, 2
Nominal traction sensor	7, 5, grinder 9
Hysteresis brake	16, 6

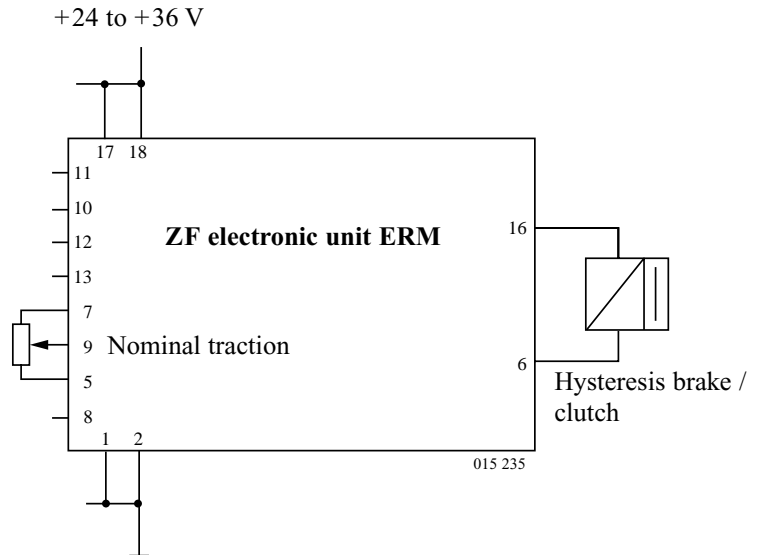

3.2.3 Technical instructions

LED: “Power” ON

Control: Torque is set by the electronic system in accordance with the nominal value input.

DIL switch setting:

Unit size coding clutch / brake,
see page 18

DIL switch setting

DIL switches							
1	2	3	4	5	6	7	8
				0	0	0	0
				0	0	0	0

Jumper position: Jumper position “2” (see 1.4, page 13) can activate further functions.

3.2.4 Startup

1. The electronic control unit is disconnected.
2. Make sure that voltage is within the range given under “1. Technical Data”!
(see page 6)
3. Check polarity (plus / minus)!

CAUTION

Unpermitted voltage and polarity may damage the installation!

4. Switch off operating voltage!
5. Connect the ERM!
6. Switch on operating voltage!
“Power” LED must light up.
7. The installation is ready for operation.

NOTE

Should the installation not function properly, consult “4. Identification and causes of failure / corrective action” (see page 38)!

3.3 Operating mode “controlled with \emptyset sensing”

3.3.1 Function diagram

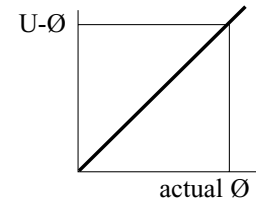
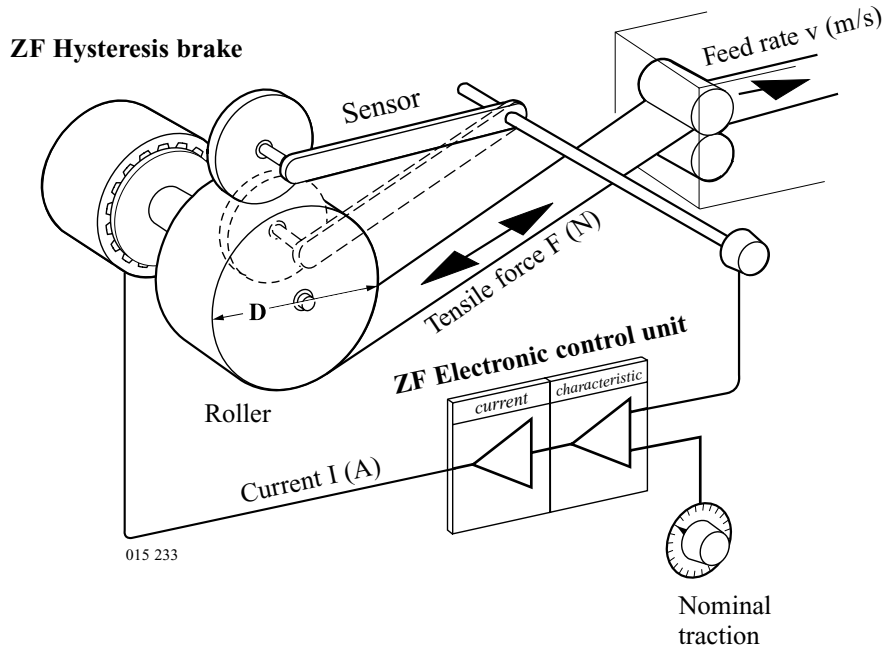

015 236

Sensor zero position equals 0 V (as shown by the broken line)

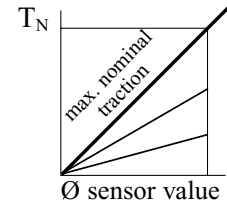

017 181

3.3.2 Pin assignment

Designation	PIN connection
Voltage supply plus 24 - 36 V	17, 18
Voltage supply ground	1, 2
Ø actual sensor	7, 5, grinder 8
Nominal traction sensor	7, 5, grinder 9
Set key	11, (17, 18)
Hysteresis brake	16, 6

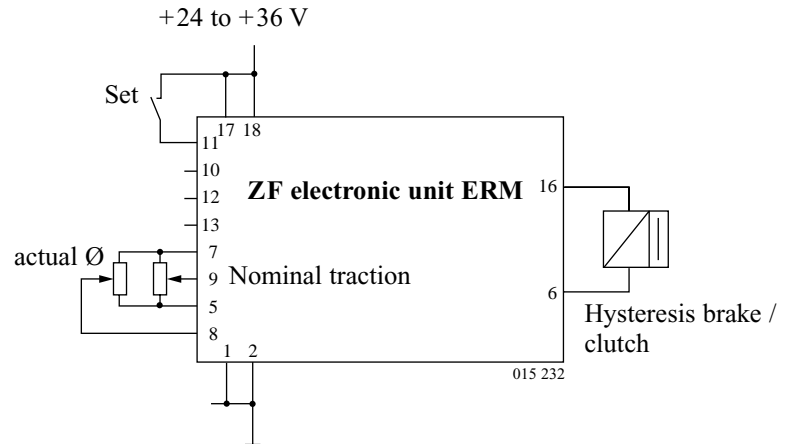

3.3.3 Technical instructions

LED: "Power" ON
 "Ø contr." flashes until the setting procedure is complete

DIL switch setting:

Controlled with Ø sensing
 Unit size coding clutch / brake,
 see page 18

DIL switch setting

DIL switches							
1	2	3	4	5	6	7	8
				1	0	0	0
				1	0	0	0
				1	0	0	0

Jumper position: Jumper position "2" and "3" (see 1.4, page 13) can activate further functions.

3.3.4 Startup

1. The electronic control unit is disconnected.
2. Make sure that voltage is within the range given under "1. Technical Data"! (see page 6)
3. Check polarity (plus / minus)!

CAUTION
Unpermitted voltage and polarity may damage the installation!

4. Switch off operating voltage!
5. Connect the ERM!
6. Switch on operating voltage!
 "Power" LED must light up.
 "Ø-Contr." LED must flash.

7. Setting of \emptyset nom. value potentiometer

- Voltage values U_{D_a} and U_{D_i} measured at random potentiometer setting.
- Nom. voltage $U_{D_{a\text{nominal}}}$ is calculated.

$Q = \frac{D_a}{D_i}$	$U_{D_{a\text{nominal}}} = \Delta U \left(\frac{Q}{Q-1} \right)$	$\Delta U = U_{D_a} - U_{D_i}$
-----------------------	---	--------------------------------

- $U_{D_{a\text{nominal}}}$ = nominal voltage outer diameter
- D_a = outer diameter
- D_i = inner diameter
- U_{D_a} = voltage outer diameter
- U_{D_i} = voltage inner diameter
- Q = diameter ratio
- ΔU = voltage difference

- Set $U_{D_{a\text{nominal}}}$ by potentiometer.

8. Set max. roller \emptyset .

9. Push “set” key.

10. Release “set” key.

Reference \emptyset is accepted,
“ \emptyset contr.” lights up.

11. The installation is ready for operation.

NOTE

Should the installation not function properly, consult
“4. Identification and causes of failure / corrective action”
(see page 38)!

3.4 Operating mode “controlled with Ø calculation”

3.4.1 Function diagram

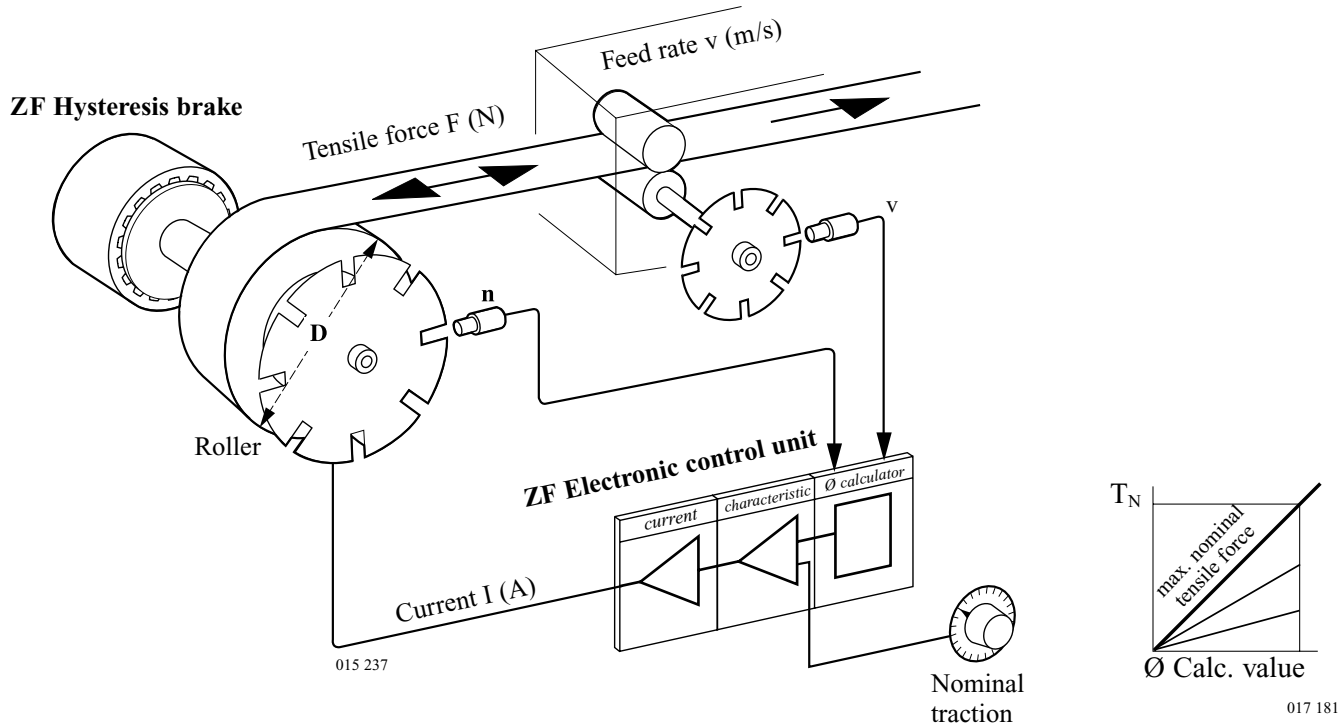

3.4.2 Pin assignment

Designation	PIN connection
Voltage supply plus 24 - 36 V	17, 18
Voltage supply ground	1, 2
Nominal traction sensor	7, 5, grinder 9
Friction factor	7, 5, grinder 8
Roller speed f_n	12
Feed rate f_v	13
Set key	11, (17, 18)
Hysteresis brake	16, 6

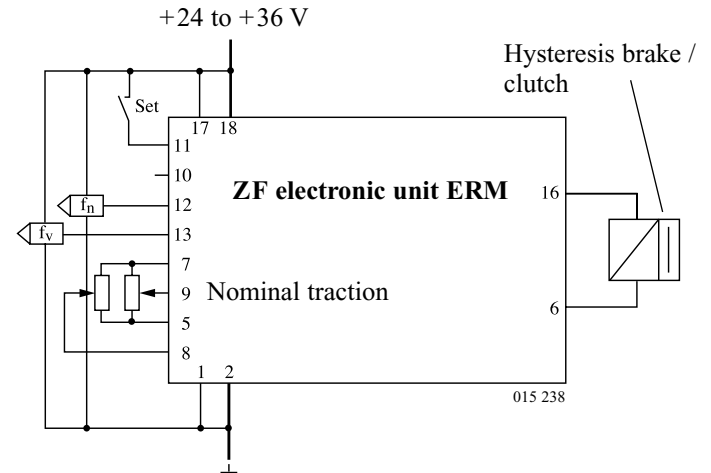

3.4.3 Technical instructions

LED: "Power" ON
 Control: "Ø contr." flashes until the setting procedure is complete

Sampling rate: updating of frequency, 10 Hz (100 ms)

Detection of web tear: ERM offers output signals for roller and feed stoppage ($f < 3$ Hz), which are evaluated and possibly identified as web tear by a machine controller.

Terminal 14: voltage if roller speed frequency < 3 Hz

Terminal 15: voltage if feed rate frequency < 3 Hz

see jumper position

** measured on PIN 17, 18.*

Compensation of friction:

With minor traction, installation friction may be relatively high compared to the brake torque needed. This must be considered when calculating the brake torque.

Determination of potentiometer voltage for the friction factor:

The friction factor is the result of the relation between friction torque and nominal torque and is expressed as voltage value and set by an additional potentiometer at terminal 8.

$$U_{\text{terminal 8}} = \frac{\text{friction torque}}{\text{nominal torque}} * 10$$

Setting of DIL switches:

Adjustable filter constant
New condition

Filter time	7	8
0.5 sec	0	0
2.5 sec	0	1
1.5 sec	1	0
0.2 sec	1	1

DIL switches								▼	▼
1	2	3	4	5	6	7	8		
				0	1				
				0	1				
				0	1				
				0	1				

Filter constant
Controlled with Ø calculation

Unit size coding clutch/brake, see page 18

DIL switch setting

Jumper position: Jumper position “1” or “2”
(see 1.4, page 13) can activate further functions.

3.4.4 Startup

1. The electronic control unit is disconnected.
2. Make sure that voltage is within the range given under “1. Technical Data”! (see page 6)

3. Check polarity (plus / minus)!

CAUTION

Unpermitted voltage and polarity may damage the installation!

4. Switch off operating voltage!
5. Connect the ERM!
6. Switch on operating voltage!
“Power” LED must light up.
“Ø contr.” must flash.
7. Set max. roller speed Ø and production speed (> 3 Hz).
8. Push “set” key.
9. Release “set” key.
Reference Ø is accepted,
“Ø contr.” lights up.
10. Installation is ready for operation.

NOTE

Should the installation not function properly, consult “4. Identification and causes of failure / corrective action” (see page 38)!

3.5 Operating mode “closed-loop control”

3.5.1 Function diagram

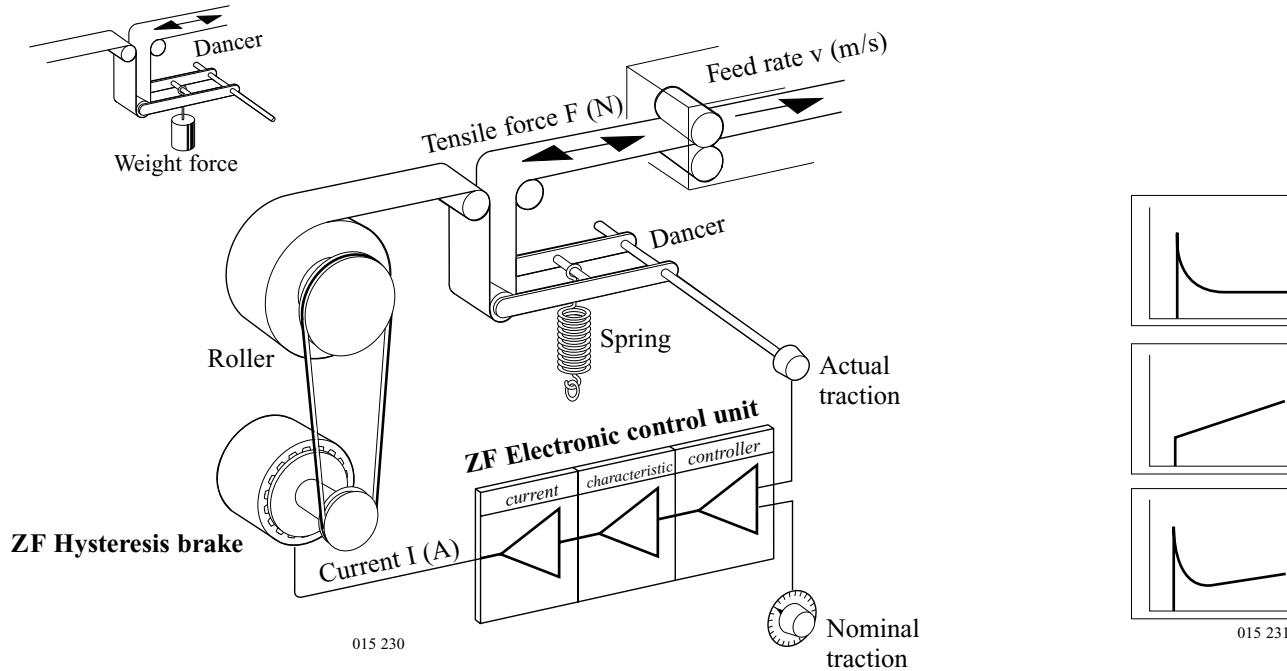

3.5.2 Pin assignment

Designation	PIN connection
Voltage supply plus 24 - 36 V	17, 18
Voltage supply ground	1, 2
Actual traction sensor	7, 5, grinder 8
Nominal traction sensor	7, 5, grinder 9
Stop key	10, (17, 18)
Hysteresis brake	16, 6

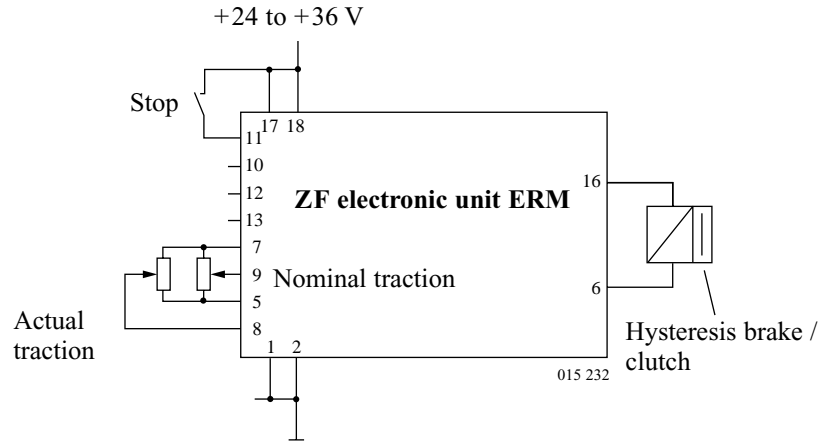

3.5.3 Technical instructions

LED: “Power” ON
 “Feedb.” ON

Stopping the installation: Stop contact blocks I portion (not necessary for PD position control).

Sampling rate: 100 Hz (10 ms)

DIL switch setting:

DIL switches							
1	2	3	4	5	6	7	8
				1	1		
				1	1		
				1	1		
				1	1		

Operating mode “closed-loop control”
 Unit size coding clutch / brake,
 see page 18

Controller transfer function, see page 19
 DIL switch setting

Jumper position: Jumper positions “2” and “3”
 (see 1.4, page 13) can activate further
 functions.

3.5.4 Startup

1. The electronic control unit is disconnected.
2. Make sure that voltage is within the range given under “1. Technical Data”! (see page 6)
3. Check polarity (plus / minus)!

CAUTION

Unpermitted voltage and polarity may damage the installation!

4. Switch off operating voltage!
5. Connect the ERM!
6. Switch on operating voltage!
 “Power” LED and “Feedb.” LED must light up.
7. The installation is ready for operation.

NOTE

Should the installation not function properly, consult “4. Identification and causes of failure / corrective action” (see page 38)!

3.6 Additional functions max-power / zero-power (I_{\max} / I_{\min})

Clutch power flow can be influenced irrespective of operating mode. Zero or max. power for ERM possible (depends on size of unit connected). Optional limitation of max. power by MobiDig 200 program.

Application / Use

- Max-power e.g. for emergency stop
- Zero-power e.g. for start-up

Activation of additional functions

Jumper on ERM board must be in **Pos. 2**. **Pos. 1** must **not** be connected!

(cf. 1.4 Jumper position).

- **Input for max-power function: Pin 15**
- **Input for min-power function: Pin 14**
- **Ground: Pin 1 or 2**

Each function remains **active** as long a signal is present on input (**low level**, cf. 1.1 Technical data).

4. Identification and causes of failure / corrective action

Failure identification	Causes	Corrective action
LED Ø contr. flashes (operating mode “controlled with Ø sensing”)		➤ Repeat setting procedure (see page 28)
LED Ø contr. flashes (operating mode “controlled with Ø calculation”)		➤ Repeat setting procedure (see page 33)
“Power” LED does not light up	No operating voltage or too low	➤ Check operating voltage
	ERM fuse is defective	➤ Replace defective fuse
	Program does not run correctly	➤ Consult ZF
All 3 LED lights will flash (sequentially)	Operating voltage too low or too high	➤ Check operating voltage
	Reference voltage too low	➤ Check load resistance
	Short-circuit or interruption at current output, or coil is bridged	➤ Correct short-circuit / interruption
	Missing size	➤ see operating mode, setting of DIL switches (see page 18)